

## INSTALLATION INSTRUCTIONS

### 2 1/2" x 7" for 1" Glass

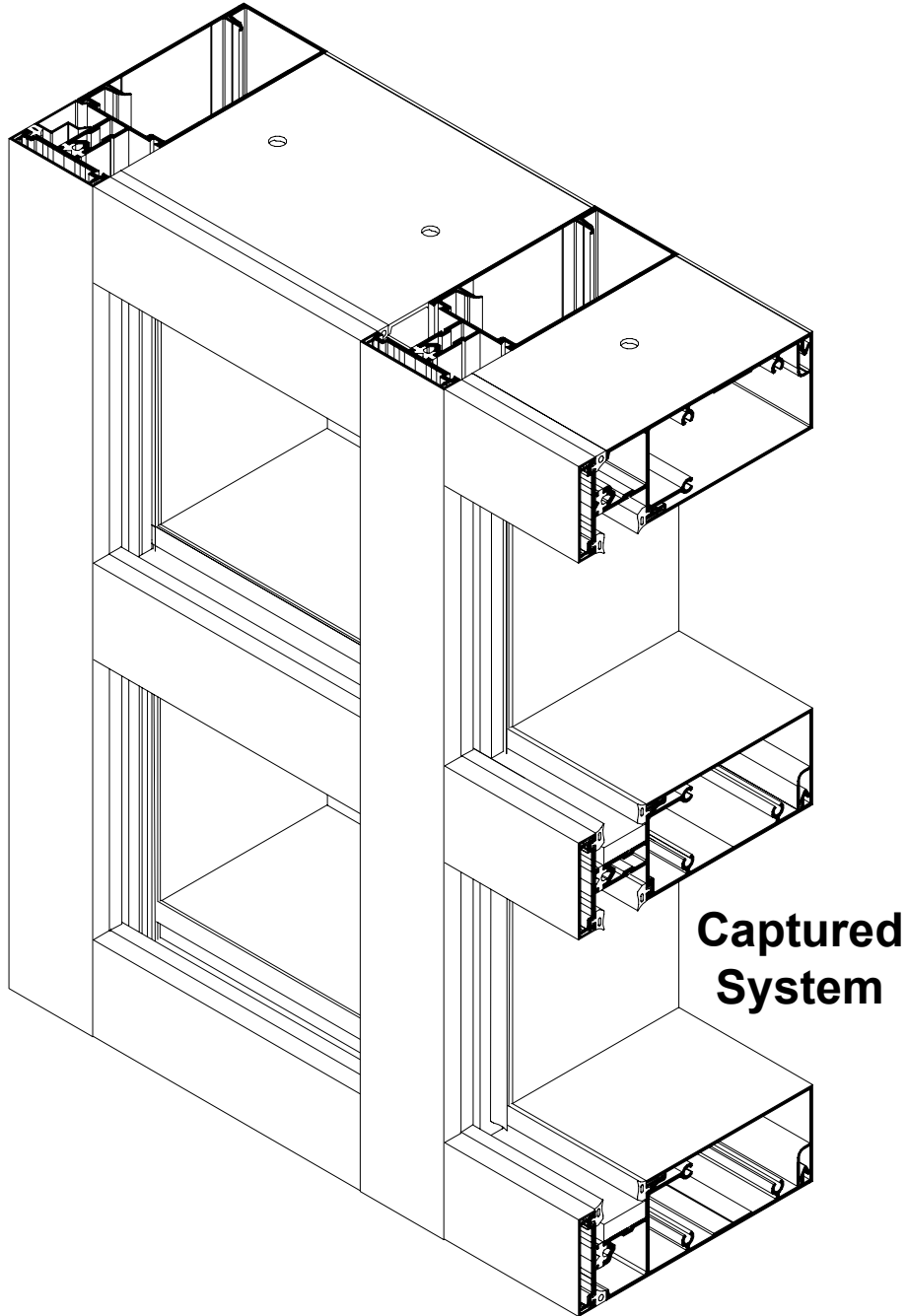

## B.G. System (Butt Glazed)

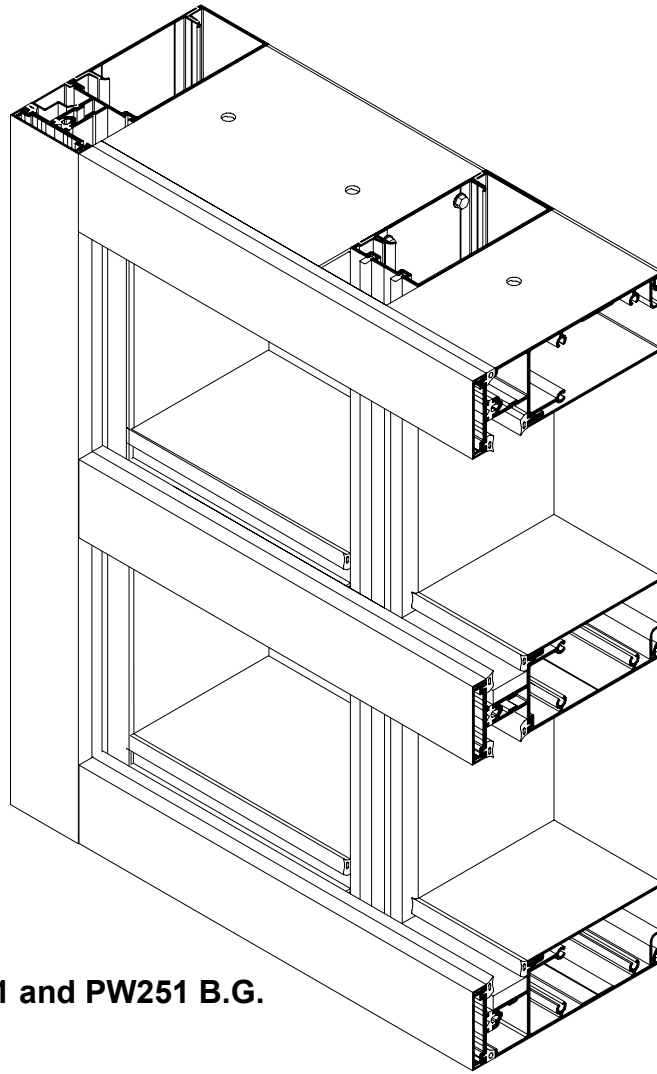

### PRODUCT FEATURES: PW251 and PW251 B.G.

#### **Glazing Features:**

- Same EPDM dense gasket used on interior and exterior at captured glass

#### **Screw spline joinery allows:**

- Coral Punch die shop fabrication
- Die set punches spline and pressure bar weep holes
- Panelized frame assembly for easy transporting and installation

#### **Pressure Bars:**

- Factory installed EPDM thermal isolator with attachment holes pre-punched 9" O.C.
- Attached to back members with #12-14 x 1-1/4" HWH #3 self-drilling screws

#### **Removable snap-on interior trim covers at all horizontals allow:**

- Anchor inspection to substrate after glazing
- Inspection and/or repair of critical joint seal areas prior to and after glazing

#### **Injection molded plastic end dams and bridges at horizontals provide:**

- Tight seals at intersection of vertical/horizontal joints for zone glazing

#### **Injection molded plastic top and bottom vertical mullion caps:**

- Accurate compression fit
- Provides continuous perimeter seal

#### **Injection molded plastic temporary glazing retainer:**

- Reduces labor
- Distributes uniform pressure on glass reducing risk of breaking glass
- Reusable for next project

# CURTAIN WALL

*These instructions are for typical installations. Reference shop drawings for special notations on installations and glazing.*

## TABLE OF CONTENTS

	<i>Page</i>
<b>General Notes</b> .....	4-6
<b>Frame Fabrication, Captured and B.G</b>	
Establishing Frame Size and Cut Lengths.....	7
Joinery Hole Locations.....	8
Steel Reinforcement.....	9
Head/Sill.....	10
Wall Jambs.....	11
Pressure Bar - Captured.....	12
Pressure Bar - B.G.....	13
Horizontal Weep Holes - Captured.....	14
Horizontal Weep Holes - B.G.....	14
<b>Frame Assembly</b>	
Gasket Installation.....	15
Joinery Tape Application.....	16
Vertical/Horizontal Joinery - Captured.....	17-20
Corner Assembly.....	21
<b>Installation</b>	
Mullion Caps.....	22
Panelized.....	23
Typical Jamb.....	24
Multi-Span Anchors, Splices and Transition Glazing.....	25-32
Perimeter Sealant Locations.....	33
End Dams and Bridges.....	34-35
Setting Blocks.....	36
<b>Glazing</b>	
Glass Formulas.....	37
Sealant at Gasket Corners.....	38
Glass Installation.....	39
Pressure Bar Installation - Captured.....	40
Pressure Bar Installation - B.G.....	41-43
Face Cover Installation & Sealing Mullion End Caps.....	44
Interior Trim Installation.....	45
<b>Entrance Subframe Installation</b> .....	46-47

# INSTALLATION INSTRUCTIONS

## - General Notes -

### RECOMMENDED GUIDELINES FOR ALL INSTALLATIONS:

- 1. REVIEW CONTRACT DOCUMENTS.** Check shop drawings, installation instructions, architectural drawings and shipping lists to become thoroughly familiar with the project. The shop drawings take precedence and include specific details for the project. Field verified notations shown within shop drawings must be resolved prior to installation. The installation instructions are of general nature and cover most conditions.
- 2. INSTALLATION.** All materials shall be installed plumb, level and true.
- 3. BENCHMARKS.** All work should start from established benchmarks and column center lines established by the architect and general contractor.
- 4. FIELD WELDING.** All field welding must be adequately shielded to avoid any splatter on glass or aluminum. Advise general contractor and other trades accordingly. All field welds of steel anchors must receive touch-up paint (zinc chromate) to avoid rust.
- 5. SURROUNDING CONDITIONS.** Make certain that construction which will receive your materials is in accordance with the contract documents. If not, notify the general contractor in writing and resolve differences before proceeding with work.
- 6. ISOLATION OF ALUMINUM.** Aluminum to be placed in direct contact with uncured masonry or incompatible materials should be isolated with a heavy coat of zinc chromate or bituminous paint.
- 7. SEALANTS.** Sealants must be compatible with all materials with which they have contact, including other sealant surfaces. Consult with sealant manufacturer for recommendations relative to joint size, shelf life, compatibility, cleaning, priming, tooling, adhesion, etc. It is the responsibility of the Glazing Contractor to submit a statement from the sealant manufacturer indicating that glass and glazing materials have been tested for compatibility and adhesion with glazing sealants, and interpreting test results relative to material performance, including recommendations for primers and substrate preparation required to obtain adhesion. The chemical compatibility of all glazing materials and framing sealants with each other and with like materials used in glass fabrication must be established.
- 8. FASTENING.** Only those fasteners used within the system are specified in these instructions. Due to the varying perimeter conditions and performance requirements perimeter fasteners are not specified in these instructions. Reference the shop drawings or anchor charts for perimeter fasteners.
- 9. BUILDING CODES.** Due to the diversity in state, local and national codes that govern the design and application of architectural products, it is the responsibility of the architect, owner and installer to assure that products selected for use on each project comply with all the applicable building codes and laws. CORAL ARCHITECTURAL PRODUCTS exercises no control over the use or application of its products, glazing materials and operating hardware and assumes no responsibility thereof.
- 10. EXPANSION JOINTS.** Expansion joints and perimeter seals shown in these instructions and shop drawings are shown at normal size. Expansion mullion gaps should be based on temperature at time of installation.

## INSTALLATION INSTRUCTIONS - General Notes -

- 11. WATER HOSE TEST.** After a representative amount of the curtain wall system has been glazed (250 square feet) and the sealant has cured, a water hose test should be conducted in accordance with AAMA 501.2 specifications to check the installation. This test should be repeated every 500 square feet during the glazing operation. Note: This test procedure should not be used for entrance doors.
- 12. COORDINATION WITH OTHER TRADES.** Coordinate with the general contractor and sequence with other trades items which offset the storefront installation such as back-up walls, partitions, ceilings and mechanical ducts.
- 13. MATERIAL HANDLING:**
- A. SHOP
    - 1. Cardboard wrapped or paper interleaved material must be kept dry.
    - 2. Immediately remove aluminum from cardboard wrapped or paper interleaved materials should it get wet to prevent staining or etching aluminum finish.
    - 3. Check arriving materials for quantity and keep record of where various materials are stored.
  - B. JOB SITE
    - 1. Material at job site must be stored in a safe place well removed from possible damage by other trades.
    - 2. Cardboard wrapped or paper interleaved material must be kept dry. (See 13.A.2)
    - 3. Keep record of where various materials are stored.
    - 4. Protect materials after erection. Cement, plaster, mortar and other alkaline solutions are very harmful to the finish.
- 14. CARE AND MAINTENANCE.** Final cleaning of exposed aluminum surfaces should be done in accordance with AAMA. 609.1 for anodized aluminum and 610.1 for painted aluminum.
- 15. CORAL ARCHITECTURAL PRODUCTS.** It is the responsibility of CORAL ARCHITECTURAL PRODUCTS to supply a system to meet the architect's specifications.
- 16. GLASS.** Glazing gaskets are designed for a compression fit against glass and can accommodate (+/- 1/32"). Be sure to check overall size of glass and thickness.

# INSTALLATION INSTRUCTIONS GENERAL NOTES SERIES PW251 - B.G. MULLION

1. **SEALANTS.** All sealants referenced in these instructions must be one part elastomeric silicone and must be applied according to the silicone manufacturer's recommendations.
2. **APPLICATION.** Structural silicone must be applied from the interior and weatherseal from the exterior.
3. **MAXIMUM ALLOWABLE STRESS ON SILICONE.** The maximum allowable size of the glass lite is controlled by the width and depth of the silicone joint combined with the specified design wind load. The stress on the structural silicone must not exceed 20 PSI for a 6:1 safety factor. Check Structural Silicone Chart in the Architectural Design Manual for this product series.
4. **ARCHITECT.** It is the responsibility of the architect to secure approval of the system and request from the Glazing Contractor the compatibility and adhesion test reports described below.
5. **GLAZING CONTRACTOR.** It is the responsibility of the glazing contractor to submit a statement from the sealant manufacturer indicating that glass and glazing materials have been tested for compatibility and adhesion with glazing sealants and interpreting test results relative to material performance, including recommendations for primers and substrate preparation required to obtain adhesion. The chemical compatibility of all glazing materials and framing sealants with each other and with like materials used in glass fabrication must be established. ***This is required on every project.***
6. **CORAL ARCHITECTURAL PRODUCTS.** It is the responsibility of Coral Architectural Products to supply a system to meet the architect's specification.

## PRODUCT APPLICATION AND INSTALLATION

Series **PW251** Panelized Curtain Wall was designed with screw spline joinery for simple fabrication and panelized installation. These features make the fabrication and installation very similar to storefront systems. **PW251** Panelized Curtain Wall should only be installed by glazing contractors employing personnel with the necessary installation and project management experience to handle these type projects.

**PW251** Panelized Curtain Wall requires the installer to pay close attention to the details shown within these **Instructions** and **General Notes**. All critical seal areas must be completed as shown.

## FRAME FABRICATION Captured or B.G. Installation

Establish frame size and cut metal to length.

### STEP 1.

Measure width of rough opening.

- A. Measure opening at bottom.
- B. Measure opening at center.
- C. Measure opening at top.

The frame width will be the smallest dimension less 1" allowing for a 1/2" minimum for shimming and caulking joint at each jamb.

Repeat process to determine frame height.

- A. Beginning on left side of opening, measure dimension from top to bottom.
- B. Repeat at center.
- C. Repeat at right side of opening.

The frame height will be the smallest dimension less 1" allowing 1/2" minimum for shimming and caulking joint at the head and sill.

### STEP 2. Vertical Members

Cut **vertical** members to size. (All vertical members run through)

Wall jambs, intermediate verticals, snap-in perimeter jamb filler and corner mullions are cut to frame height.

- A. Pressure bars are cut frame height minus (-) 1/4".
- B. Face covers are cut frame height minus (-) 1/4".
- C. Vertical glazing adaptors D.L.O. (+) 1".
- D. Reference Pages 30-31 for vertical mullions with a splice joint.

### STEP 3.

#### Captured - Horizontals

Cut **horizontal** members to size.

- A. Head, sill and intermediate mullions are cut D.L.O.
- B. Pressure bars are cut D.L.O. minus (-) 1/4".
- C. Face covers are cut D.L.O. minus (-) 1/32".
- D. Interior snap-on trim is cut D.L.O. minus (-) 1/32"
- E. Horizontal glazing adaptors D.L.O. (-) 1/8"  
(Reference **page 29**)

#### B.G. - Horizontals

Cut **horizontal** members to size.

- A. Head, sill and intermediate mullions are cut D.L.O.
- B. Pressure bars run continuous between wall jambs.  
See **page 42, Detail "A"** for splice joints when req'd.
- C. Face covers run continuous between wall jambs.  
See **page 43, Detail "C"** for splice joints when req'd.
- D. Interior snap-on trim is cut D.L.O. minus (-) 1/32"
- E. Horizontal glazing adaptors D.L.O. (-) 1/8"  
(Reference **page 29**)

Mullion spacing **tolerance** accumulation **build up** may become a problem on wide multi-bay elevations. Frequently check the cut lengths of head, sill and intermediate horizontal members prior to assembly to prevent tolerance build up. It is also good practice to check overall frame width every four or five bays during installation.

# FRAME FABRICATION

## Joinery Hole Locations

### STEP 4.

Use **DJ251** drill jig or **PW251 Punch Die Set** for hole fabrication in verticals for attaching horizontals.

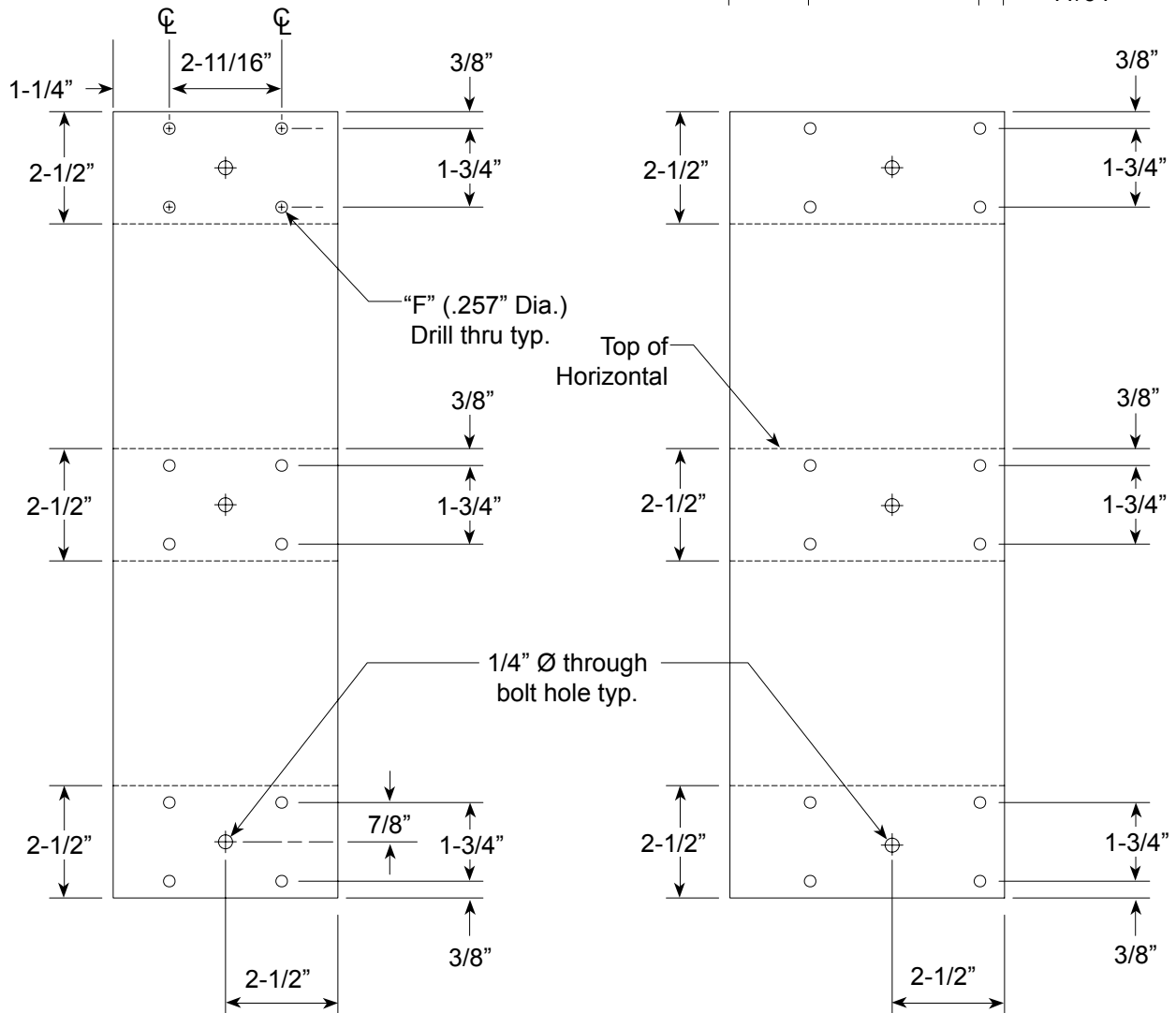
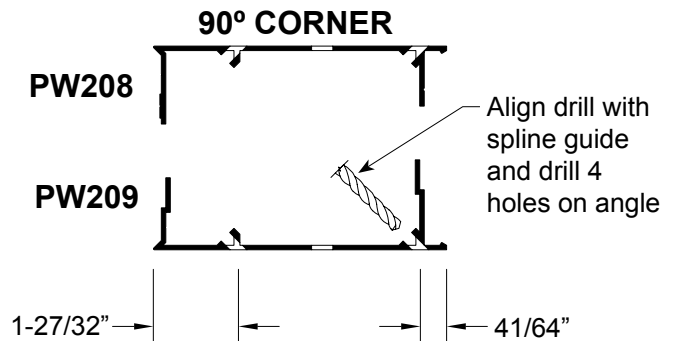
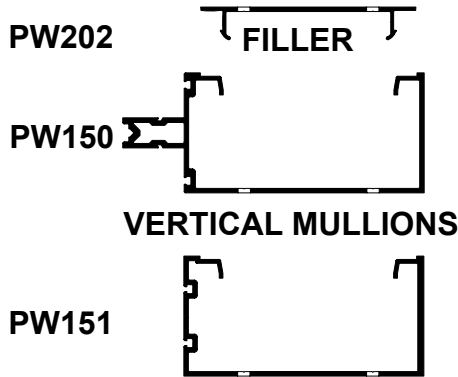
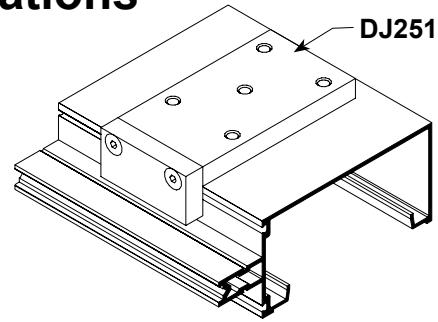



# FRAME FABRICATION

## Steel Reinforcement

### STEP 5.

Fabricate steel reinforcement where required. Cut steel 1" less than length of vertical mullion.

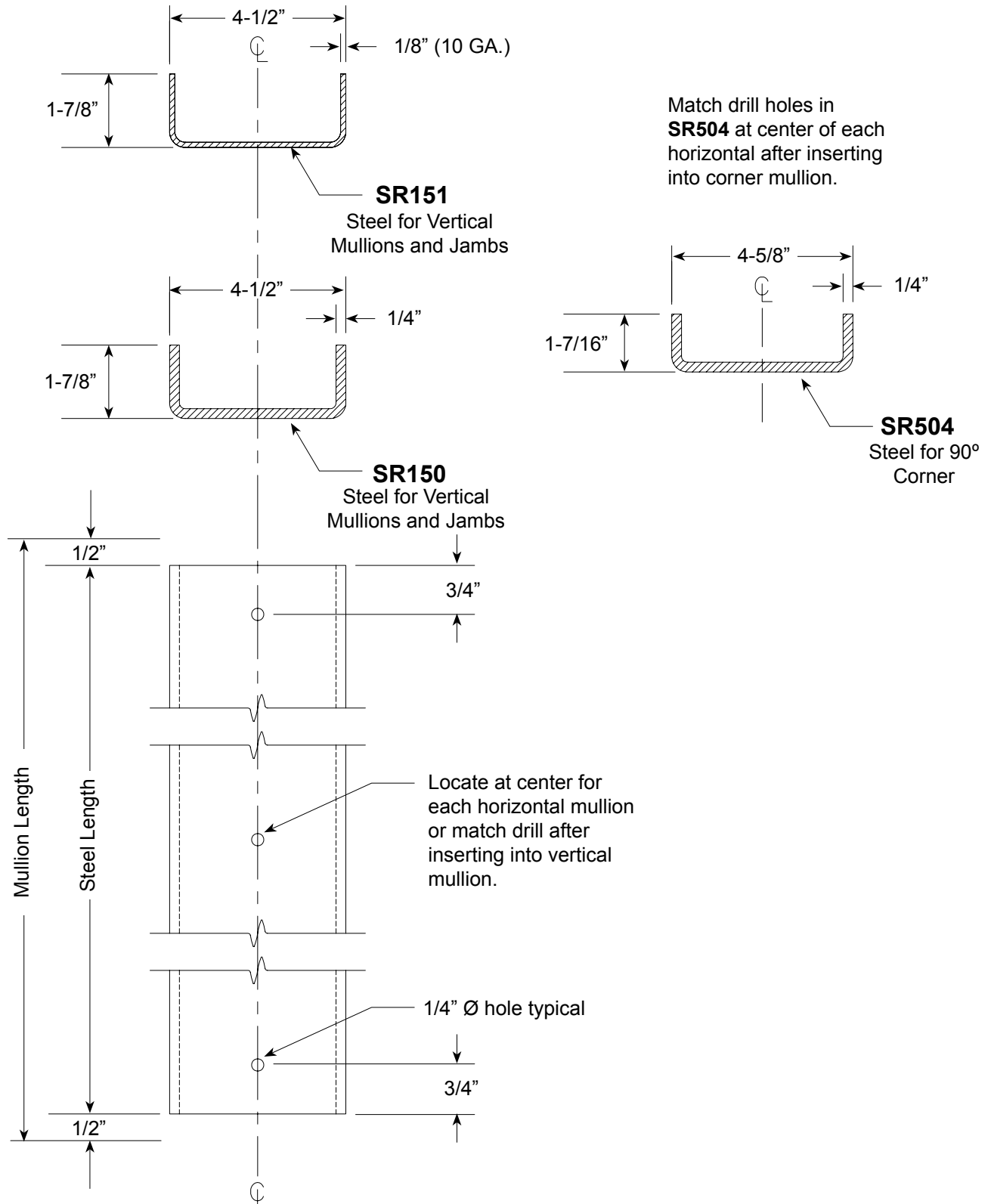

## FRAME FABRICATION

### Head / Sill

**STEP 6.**

Fabricate head and sill anchor holes. Drill or punch one (1) ea. anchor hole located approximately 4" from each end of part. Hole should be centered on "V" groove located in extrusion. When two (2) or more fasteners are required, locate each additional fastener at minimum spacing as required for substrate.

**Note:** Hole Ø may vary depending on bolt size required for meeting job specific wind load conditions. Reference **CAP anchor charts** for typical conditions.

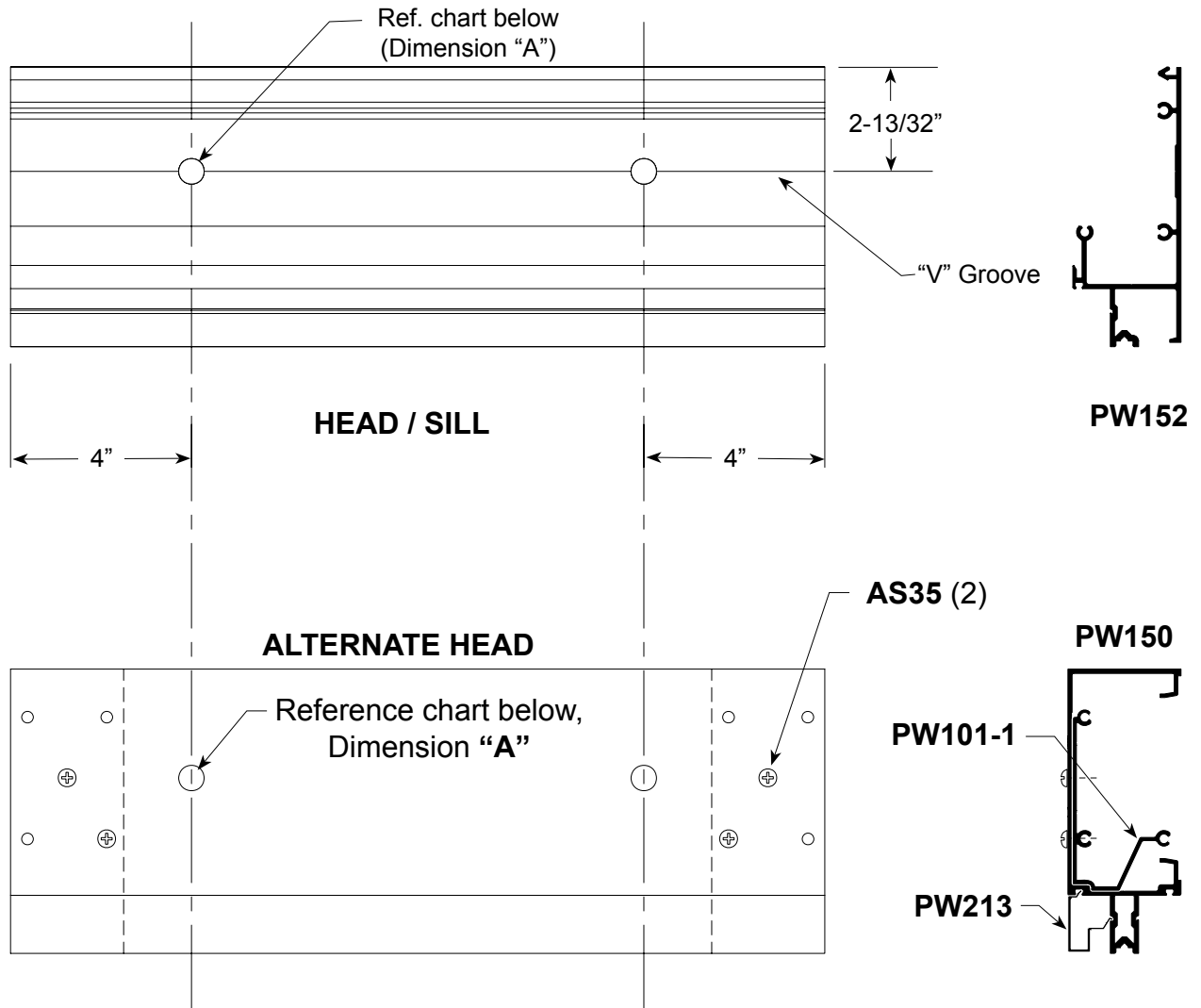

Punch or drill (Reference **page 8**) holes in each end of **PW150**. Attach **PW101-1** spline anchor clip in each end using, 2 each, **AS35** (#14 x 1" FHP self drilling fastener).

ANCHOR BOLT Ø	DIMENSION "A"
3/8"	7/16"
1/2"	9/16"

# FRAME FABRICATION

## Wall Jamb

**STEP 7.**

Fabricate for wall jamb using **PW150**, **PW202** and **PW213**.



**PW202**  
Flat Filler



**PW213**  
Snap-in  
Pocket Filler

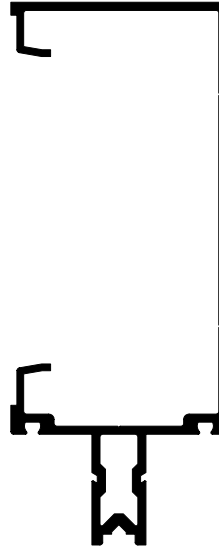

**PW150**  
Vertical Mullion

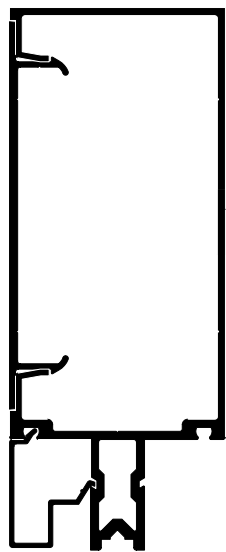

**Single Span**

3/4" Access Hole

Wall Jamb

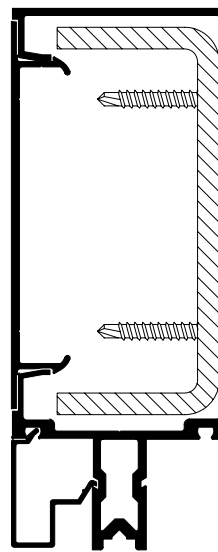

**Multi-Span**

Locate 8" long **SR150-1** tapping plate at anchor location for multi-span conditions. Reference **page 26, Detail "C"**.

# FRAME FABRICATION

## Pressure Bar - Captured

### STEP 8.

Fabricate vertical and horizontal pressure bars.

Holes for attaching **PW204-1** pressure bars are pre-punched at factory 9" on center. The 1/4" Ø holes located 1-1/2" from each end of pressure bar will need to be added as shown below. Drill hole on "V" groove line.

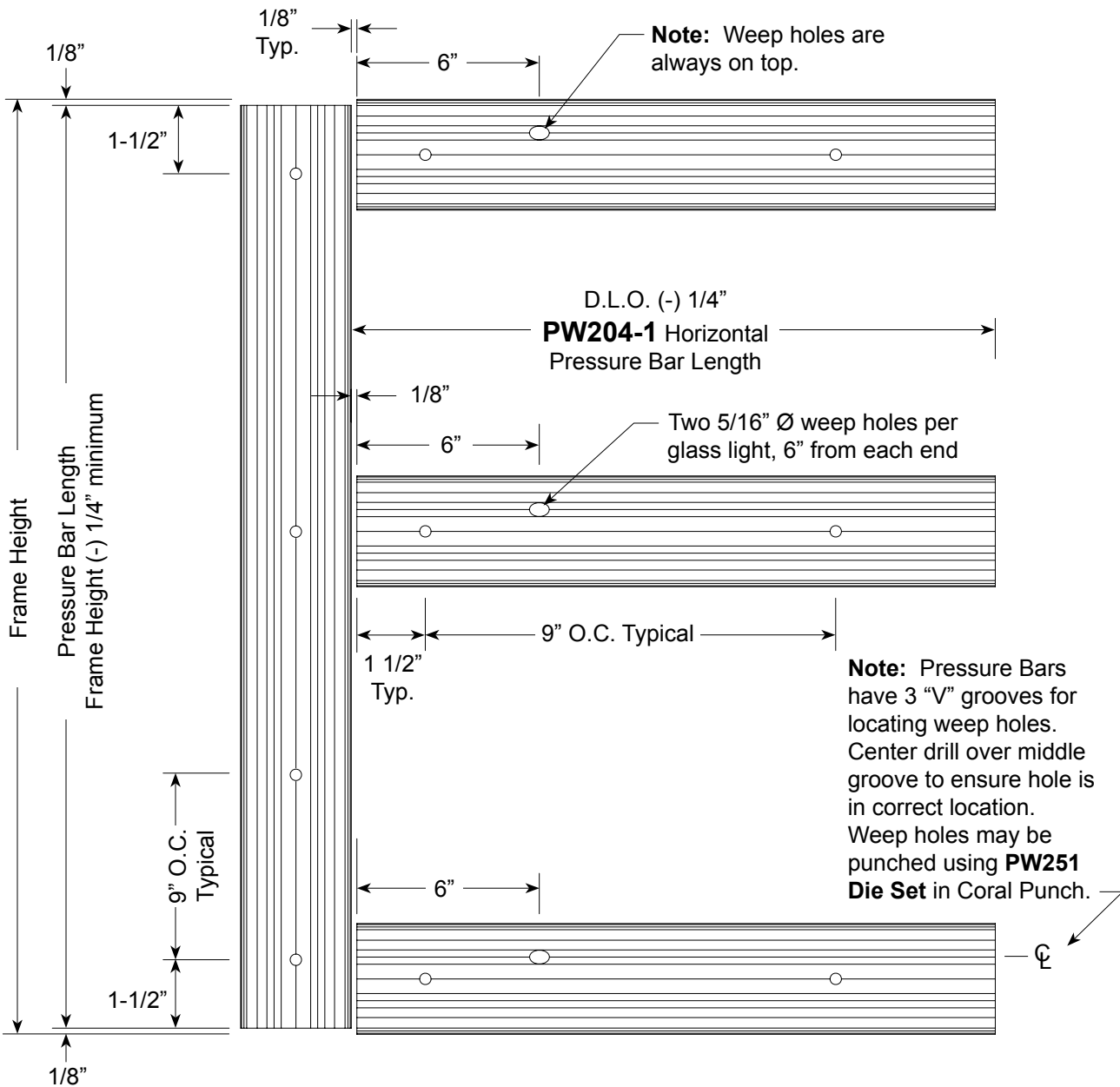

**Note:** It is very important to ensure that vertical pressure bars are cut short to prevent dislodging **SP209** top & bottom mullion caps.

# FRAME FABRICATION

## Pressure Bar - B.G.

### STEP 9.

Fabricate vertical and horizontal pressure bars.

Holes for attaching **PW204** pressure bars are pre-punched at factory 9" on center. The 1/4" Ø holes located 1 1/2" from each end of pressure bar will need to be added as shown below. Drill hole on "V" groove line.

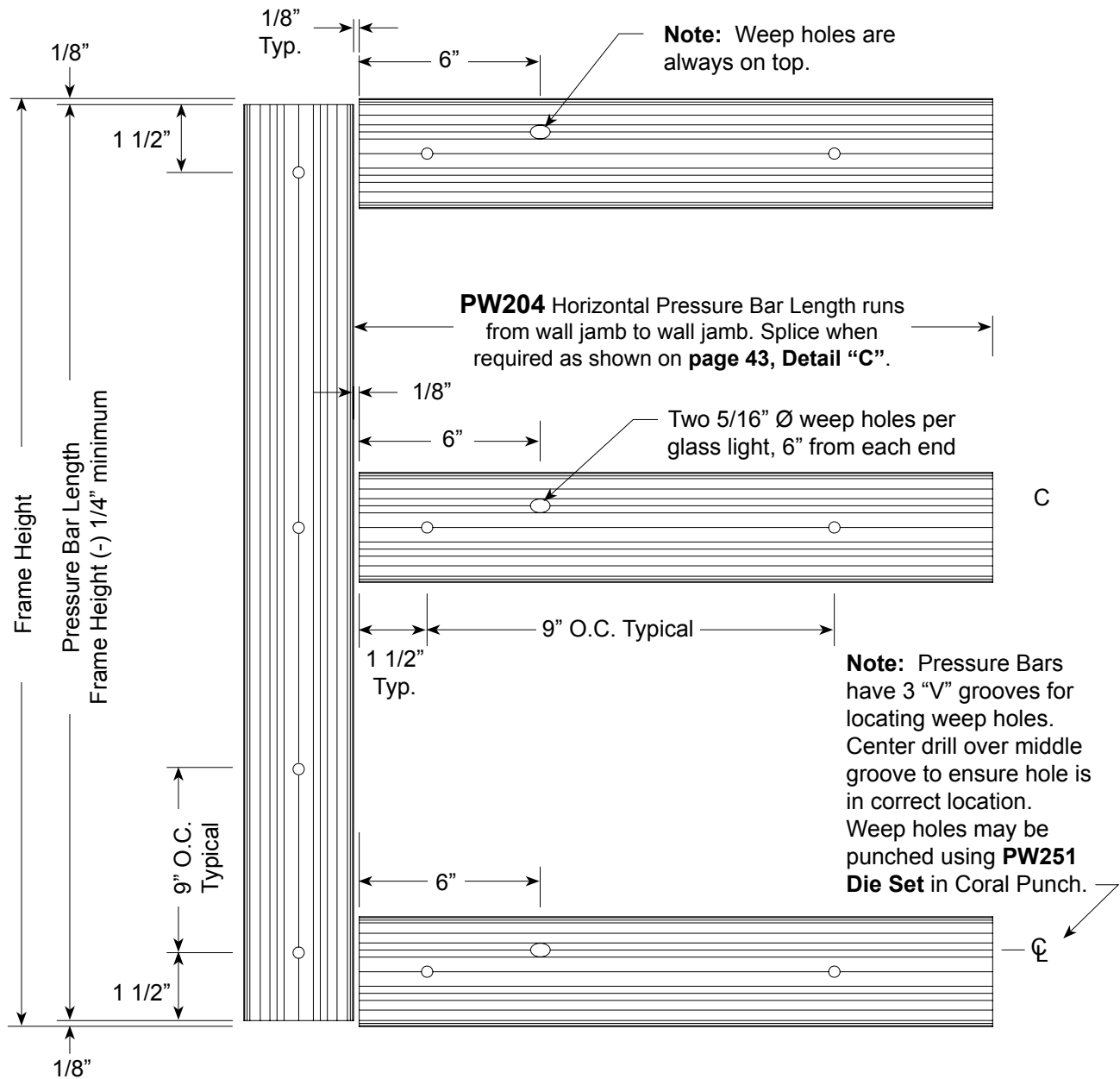

**Note:** It is very important to ensure that vertical pressure bars are cut short to prevent dislodging **SP209** top & bottom mullion caps.

## FRAME FABRICATION

### Weep Holes for Horizontal Covers

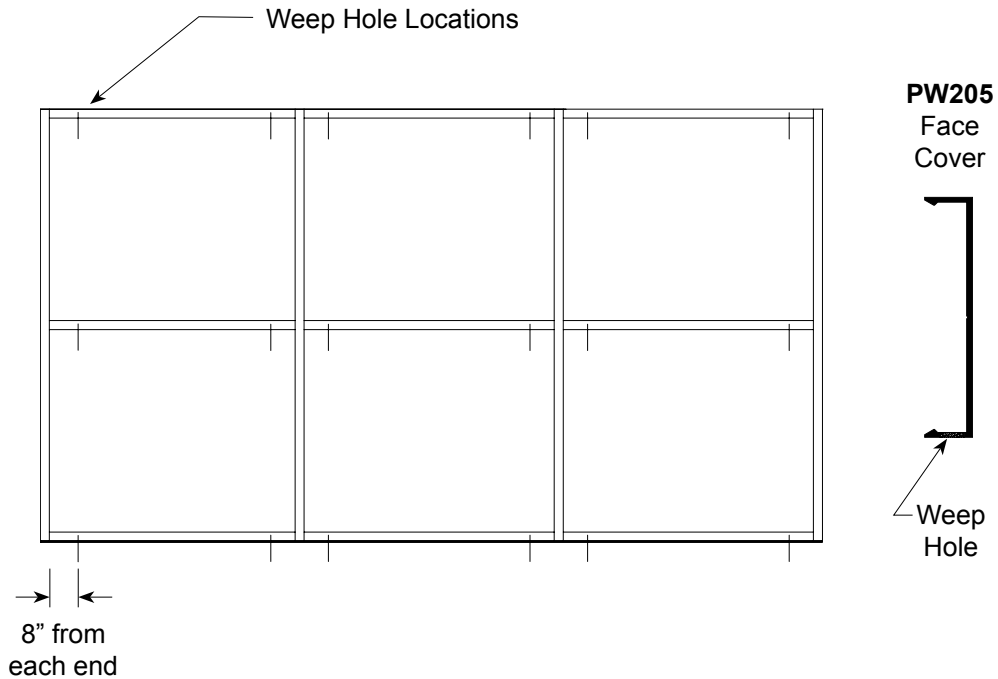

#### STEP 10. Captured Installation

Fabricate horizontal face covers for 1/4" Ø weep holes. Install covers with weep holes located on the underneath side.

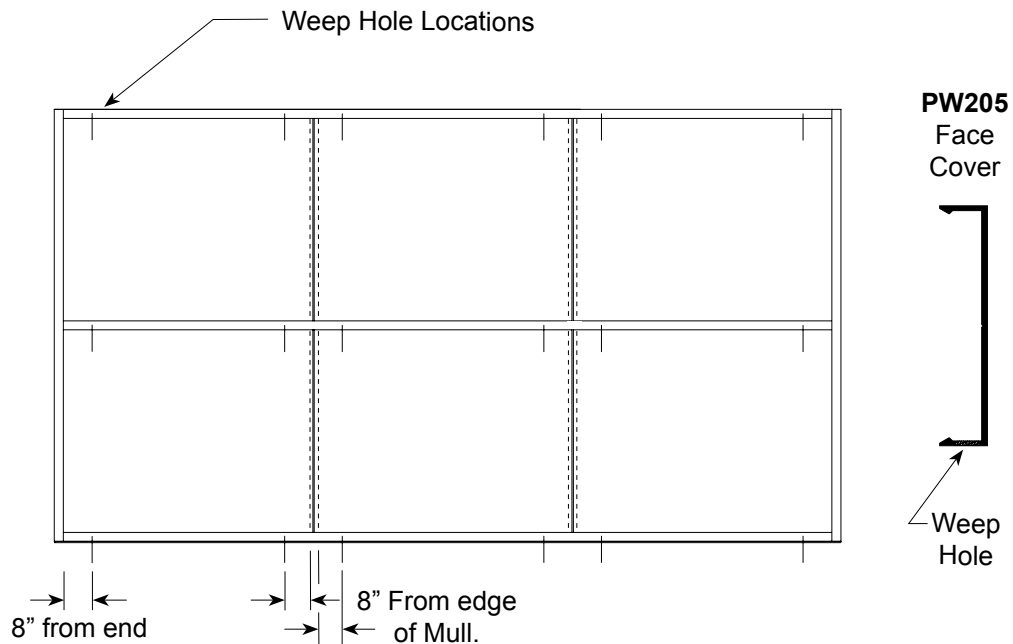

#### STEP 11. B.G. Installation

Fabricate horizontal face covers for 1/4" Ø weep holes. Install covers with weep holes located on the underneath side when snapping on covers. See **page 43** for splice joints.

## FRAME ASSEMBLY Gasket Installation

### STEP 1.

Prior to assembly of frames, install the following gaskets into the fabricated framing members:

Back Members: **NG10**

Intermediate Pressure Bars: **NG10**

Perimeter Pressure Bars: **NG10** (against glass) and **NG11** (against aluminum)  
(Reference **Detail “A”** on **page 42**).

Spacer gasket for B.G. Mullion: **NG14**

### **GASKET INSTALLATION PROCEDURES** (*Do not stretch gaskets*)

1. Cut gaskets allowing for 1/8” extra length per foot of framing members to accommodate shrinkage.
2. **NG10** gaskets for vertical back members are cut D.L.O. plus 1-1/4”.  
(Reference **Detail “A”** on **page 38**).
3. **NG14** Vertical spacer gasket runs full length on **PW151** B.G. mullion.  
(Reference **Detail “B”** on **page 38**).
4. Horizontal spacer gasket is cut to D.L.O. length.
5. Horizontal pressure bar: glazing gasket should extend 1/8” beyond end of pressure bar.
6. Vertical pressure bar: gasket runs full length.

## FRAME ASSEMBLY Joinery Tape Application

### STEP 2.

#### GLAZING TAPE INSTALLATION PROCEDURES: *Ref. Step 3.*

1. Cut **SM5601** 1/8" x 1/2" tack tape approximately 2-3/4" long.
2. Clean surfaces where tape is to be applied with isopropyl alcohol or solvent to remove all dirt and cutting oils. Allow surface to dry before applying tape.
3. Position tape on vertical mullions at horizontal joint intersections.
4. Just prior to frame assembly, remove protective cover and screw joints together.
5. Use a box knife to trim excess sealant tape where exposed. Do not pull tape to trim.

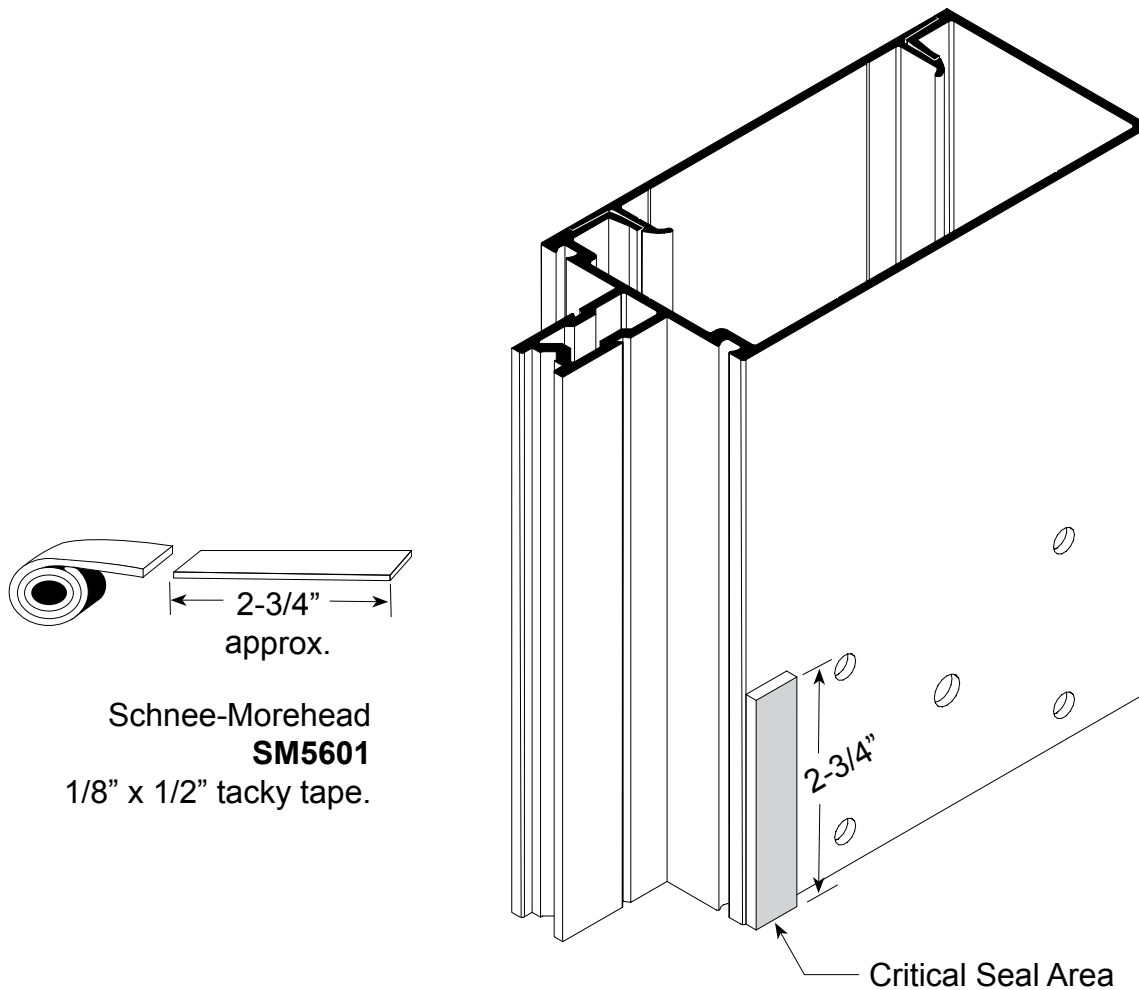



# CAPTURED FRAME ASSEMBLY Vertical to Horizontal Joinery

STEP 3.

**Note:** Reference page 38, Detail "A" for NG10 Gasket location in vertical. (D.L.O. + 1-1/4")

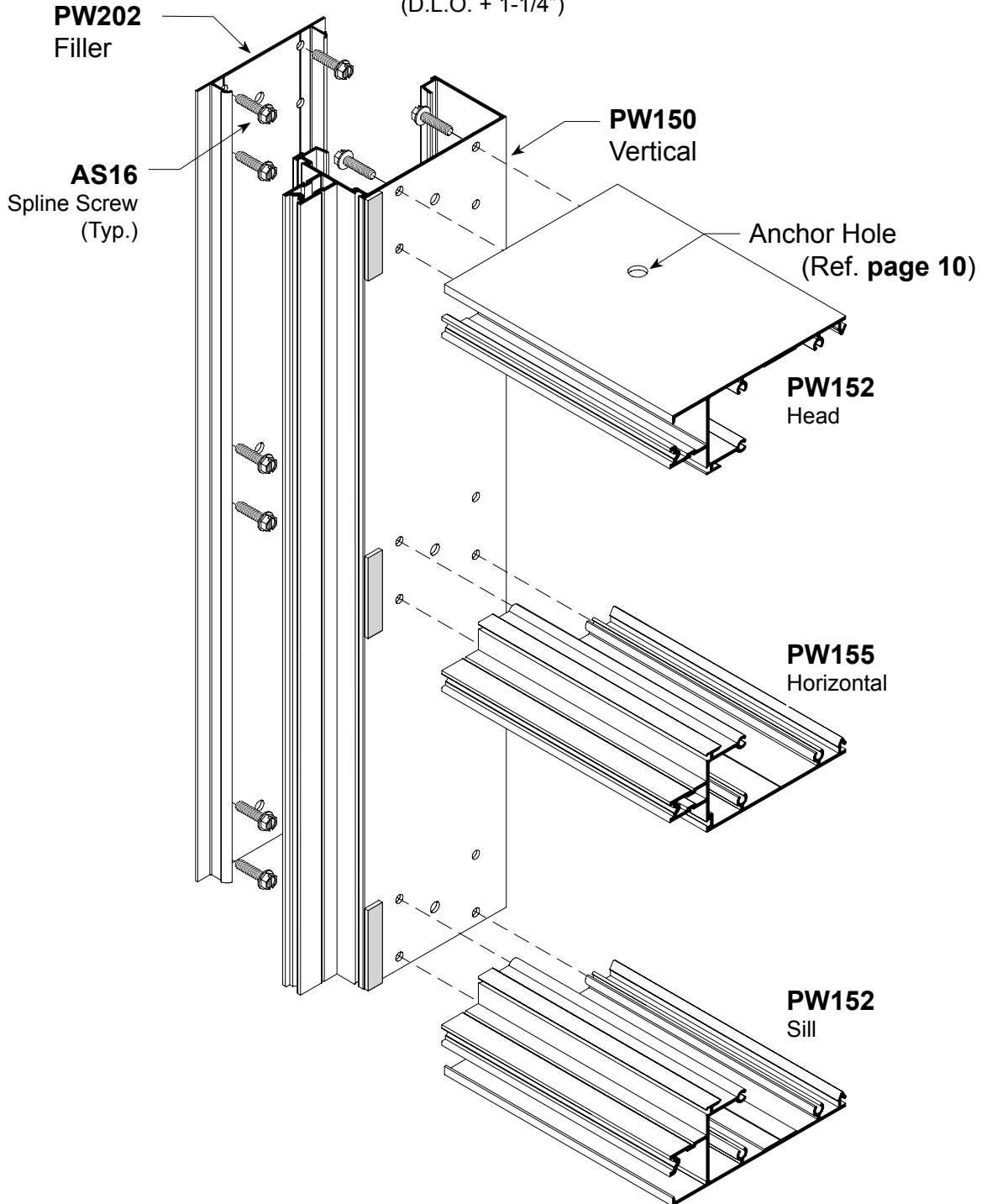

# B.G. MULLION FRAME ASSEMBLY

## Vertical to Horizontal Joinery

STEP 4.

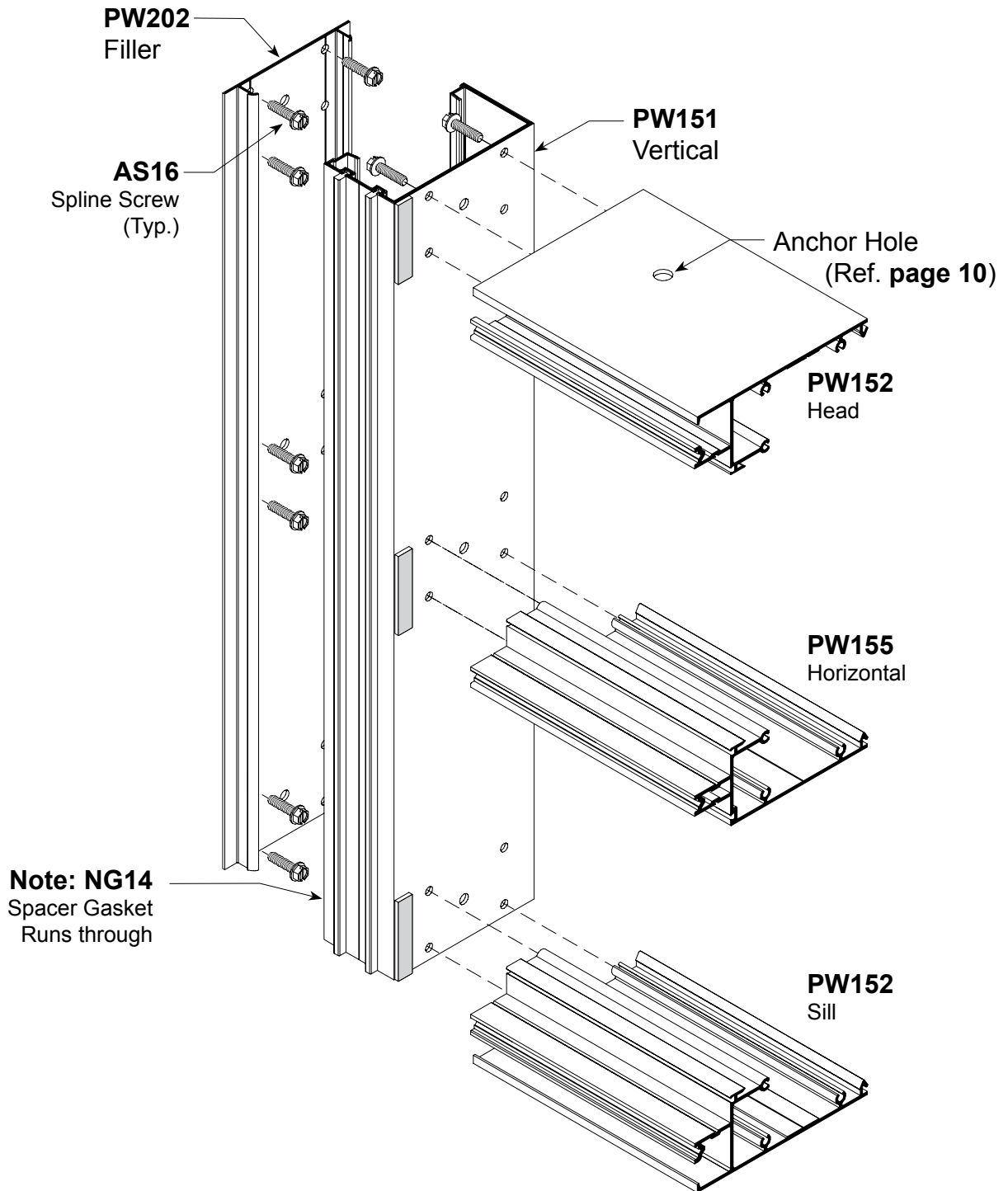

# WALL JAMB ASSEMBLY Vertical to Horizontal Joinery

## STEP 5.

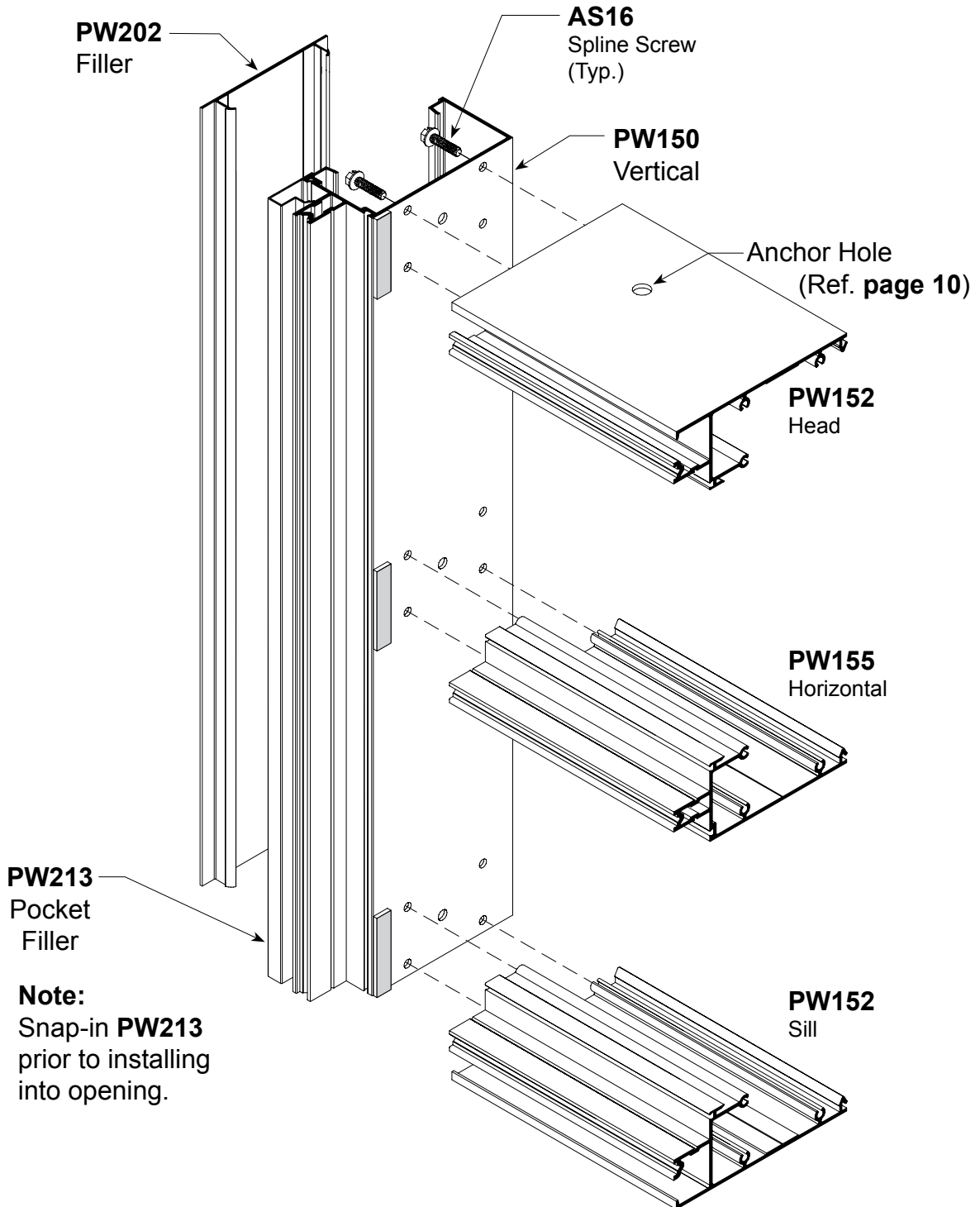

# OUTSIDE CORNER ASSEMBLY Corner to Horizontal Joinery

## STEP 6.

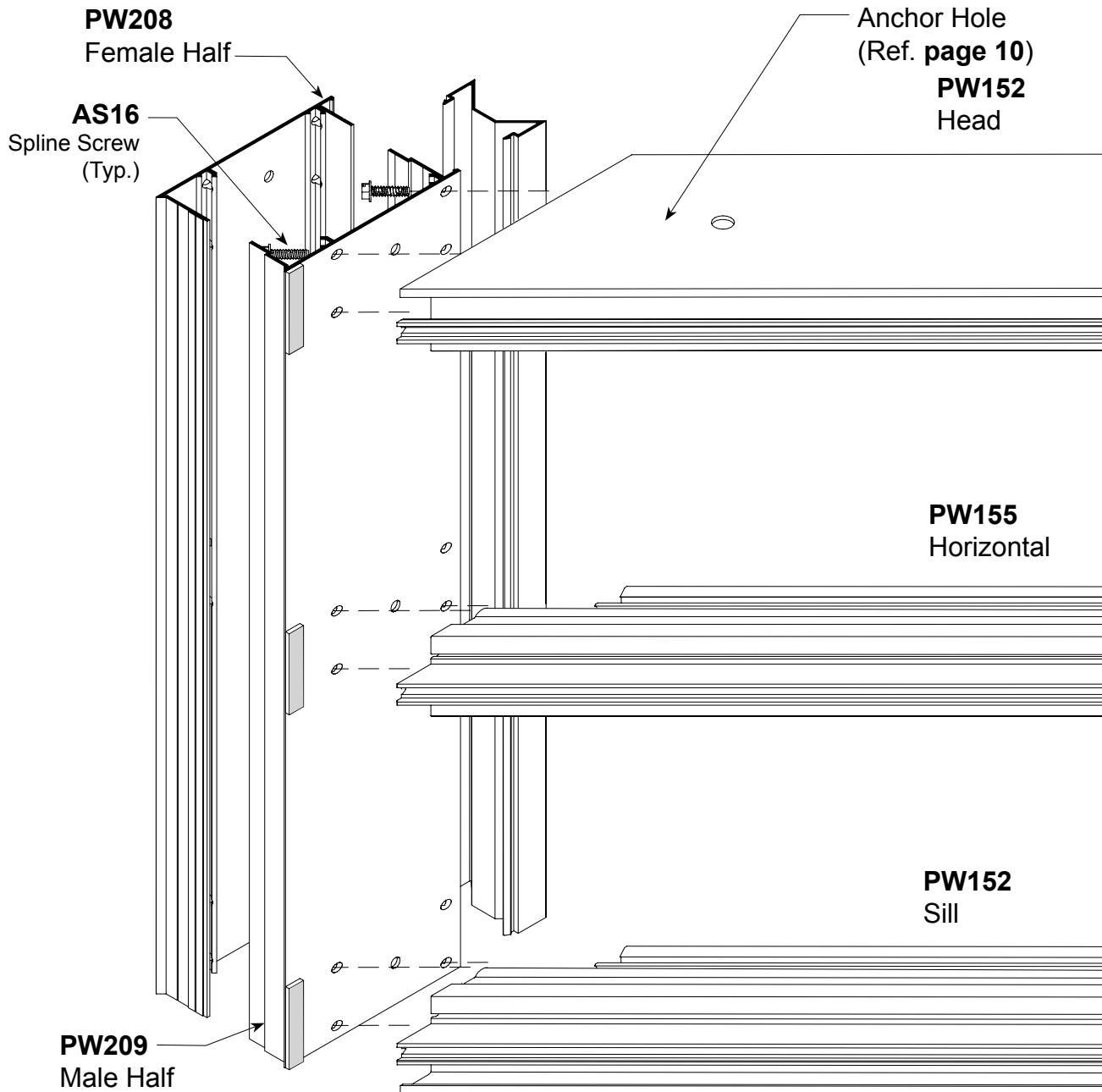

# OUTSIDE CORNER ASSEMBLY

## Corner Assembly Fasteners

**STEP 7.**

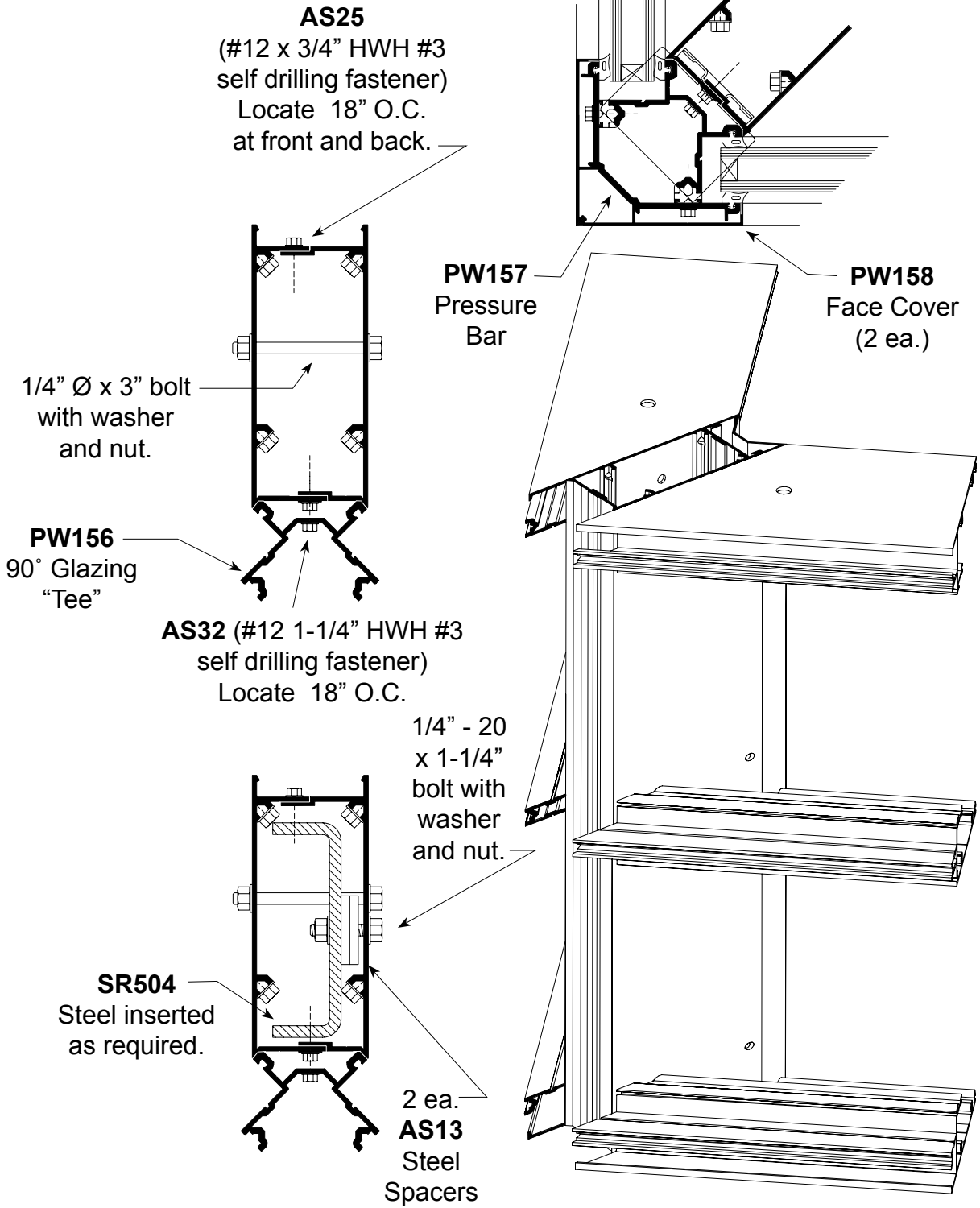

## MULLION CAP INSTALLATION Captured and B.G.

**STEP 8.** Prior to installing frames into opening, install injection molded plastic **SP209** mullion caps at top and bottom of vertical members as shown below to ensure continuous perimeter seal.

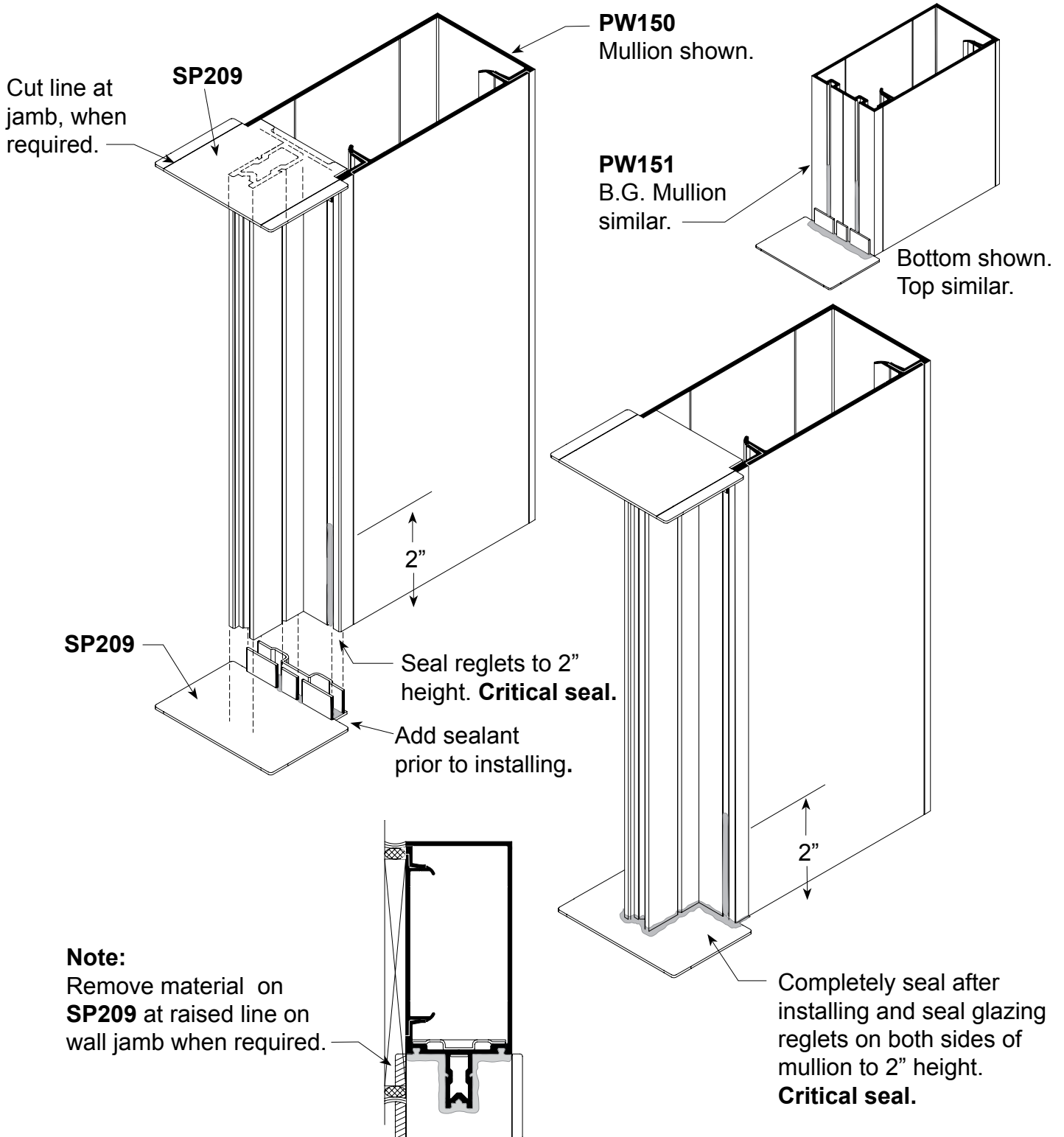

# FRAME INSTALLATION Panelized Assembly

## STEP 1.

Install assembled frame panels into opening starting with jamb and continue working toward the last bay until the last panel is installed. Reference illustrations shown below for sequencing.

**Note:** Snap-in **PW202** flat filler and **PW213** pocket filler into jambs prior to installing. **PW213** is difficult to install after jambs are installed due to limited work space.

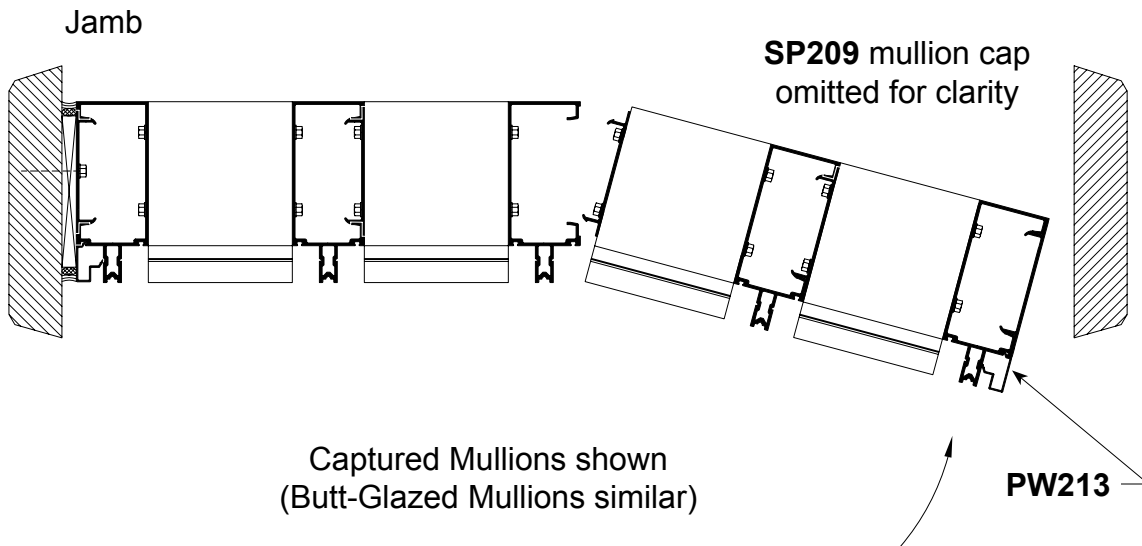

# TYPICAL JAMB INSTALLATION

## STEP 2.

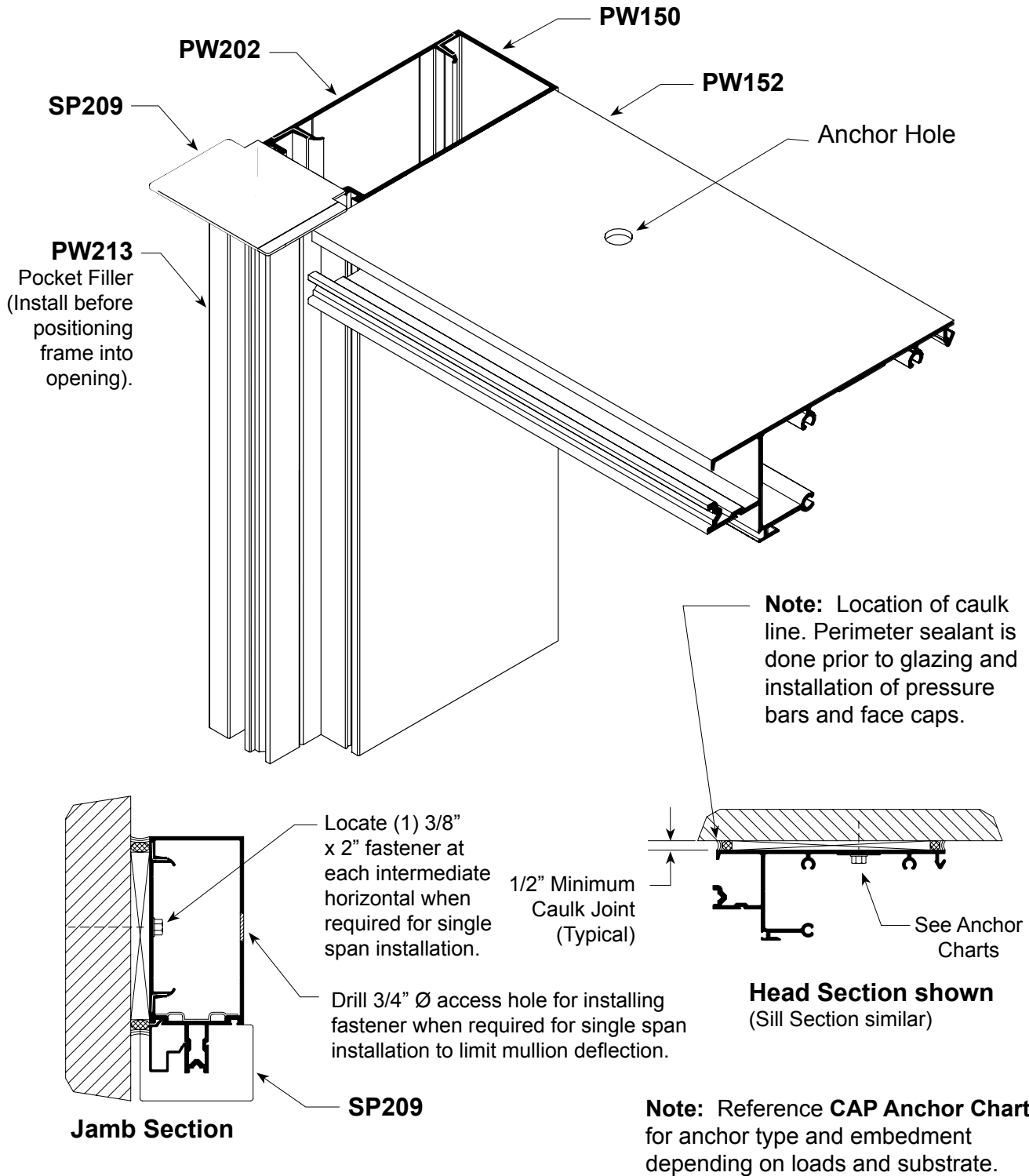



# STEEL ANCHOR INSTALLATION

## Multi-Span Condition

**Details A and B** show fixed (dead load) and expansion (wind load) anchors. Anchor type, size and quantity vary per job requirements. Details shown are to be used as a guide only. See approved shop drawings for actual conditions.

**Step 1.** Secure verticals to anchor clips after alignment has been completed.

**Note:** Mullion spacing must be held to within  $\pm 1/32"$ . Check overall frame dimension every four bays to monitor dimension build up.

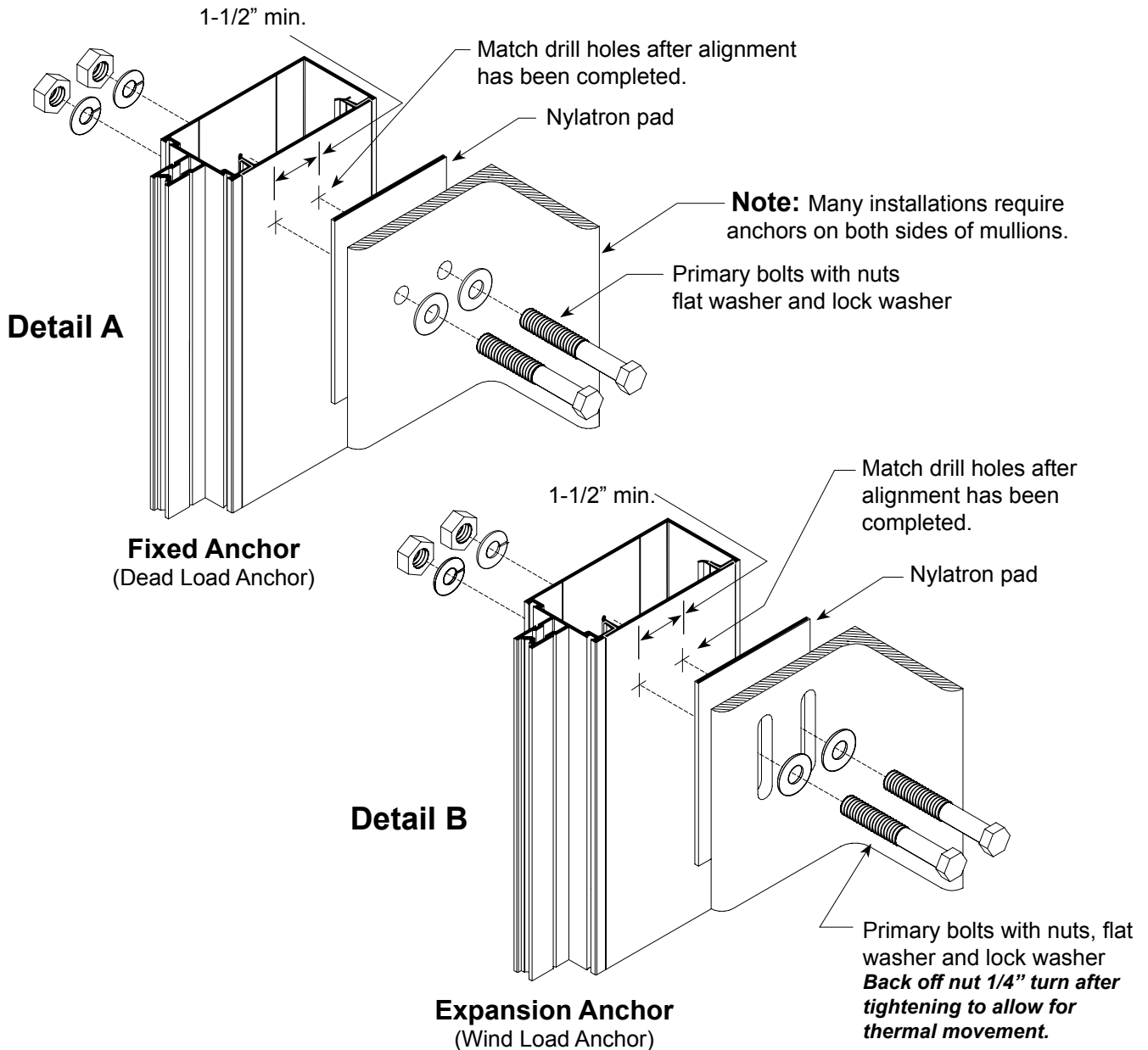

# JAMB ANCHOR INSTALLATION Multi-Span Condition

## STEP 2.

**Note:** Details shown are to be used as a guide only. See approved shop drawings for actual conditions.

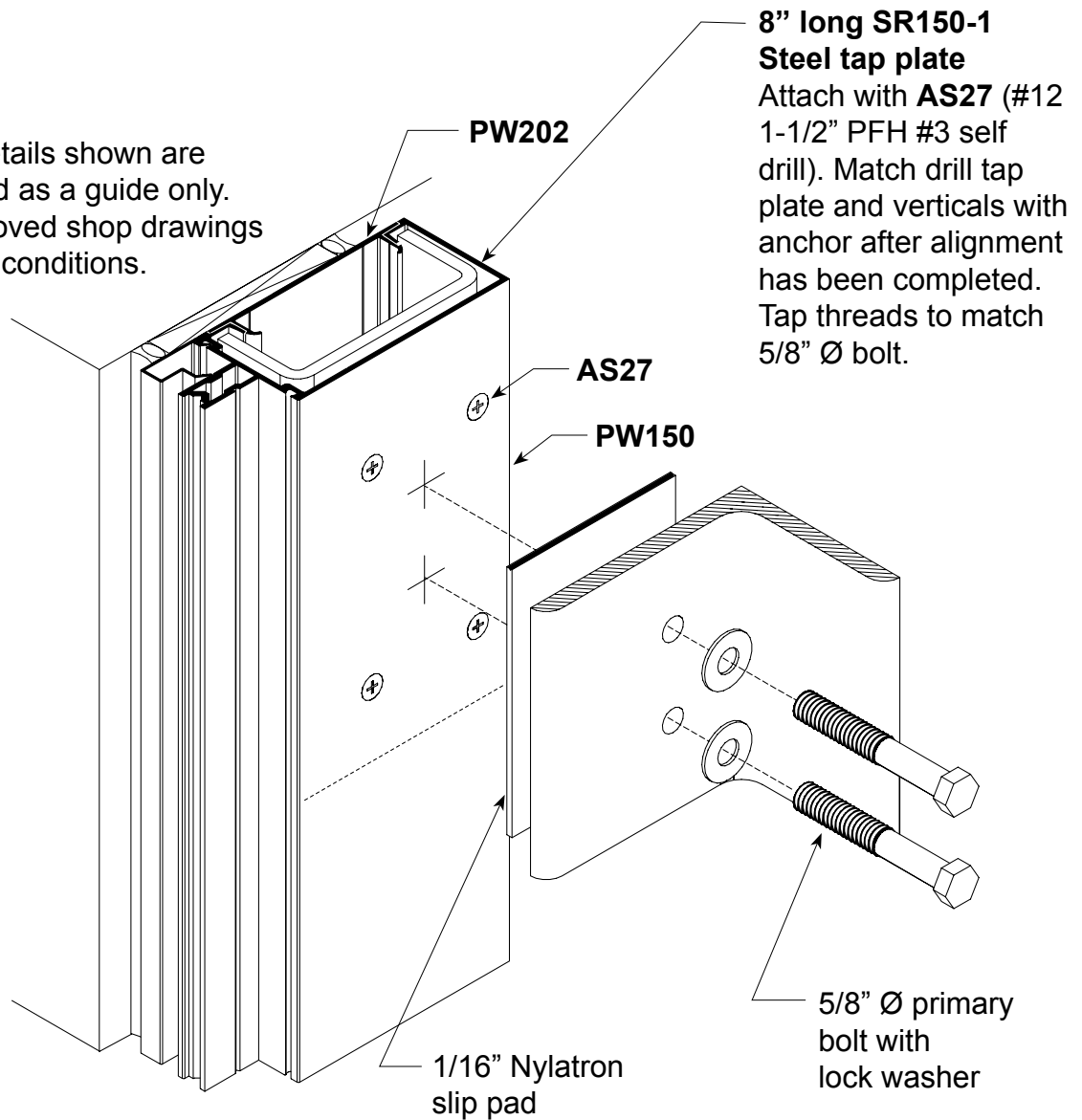

**Detail C**  
**Fixed Anchor**  
(Dead Load) shown

**Note:** Reference **Detail B** on **page 25** for wind load anchor.

## SPLICE DETAIL Vertical Mullion - Multi-Span

### STEP 3.

1. Clean splice sleeves and all joint surfaces. Apply bond breaker tape at areas where sleeve will be sealed to avoid three side adhesion.
2. Slide sleeve into the upper member before it is installed and use duct tape to hold it in retracted position.
3. Install **AS25** stop screw 2-7/8" from top of lower member as shown below.
4. Install upper member, remove duct tape and let extruded sleeve slide down until it rests on top of stop screw.
5. Seal joint over sleeve as shown on **Detail "F"** (page 28). Stagger joints on back members, pressure bars.

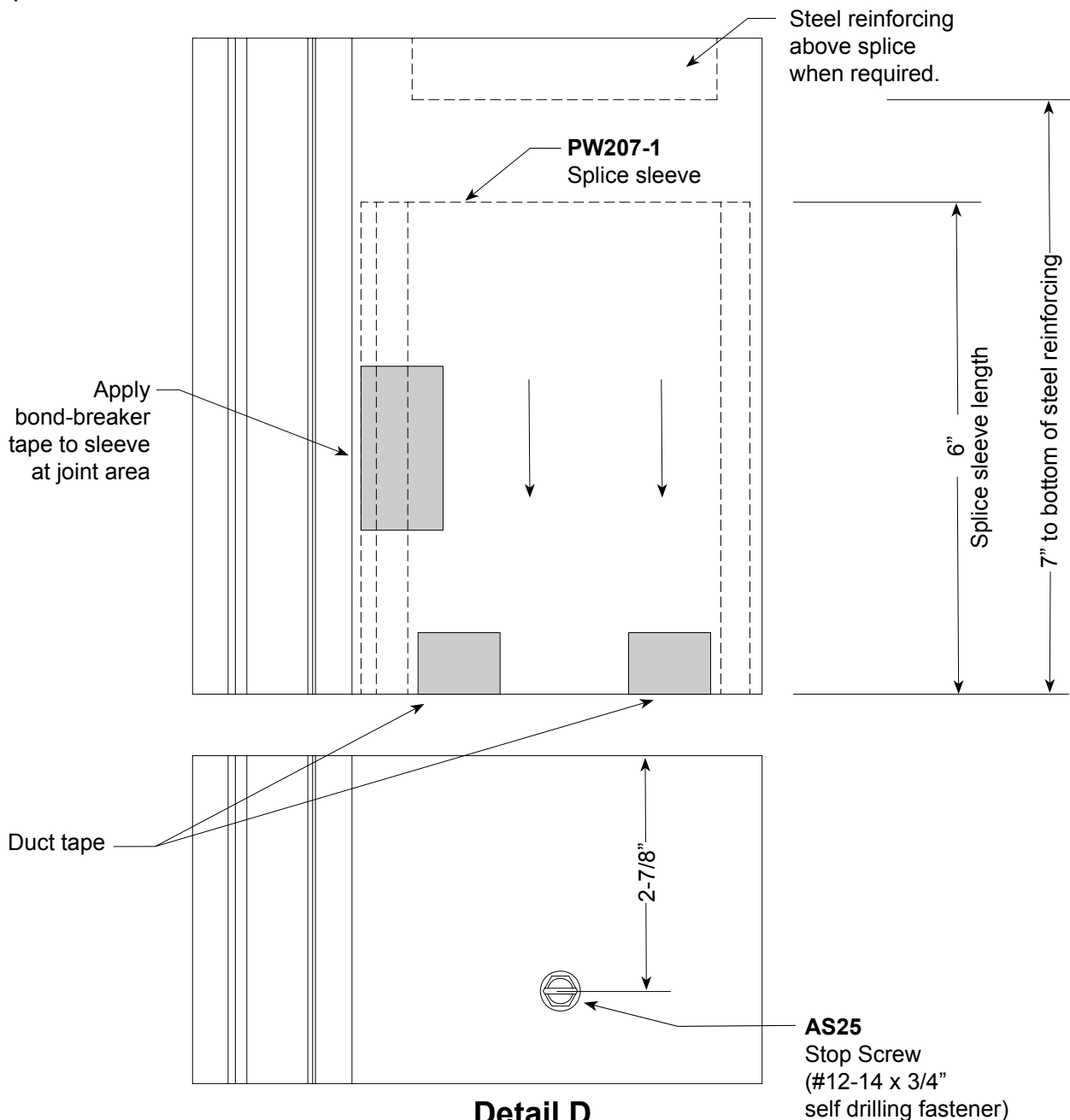

# SPLICE DETAIL

## Vertical Mullion - Multi-Span

### STEP 4.

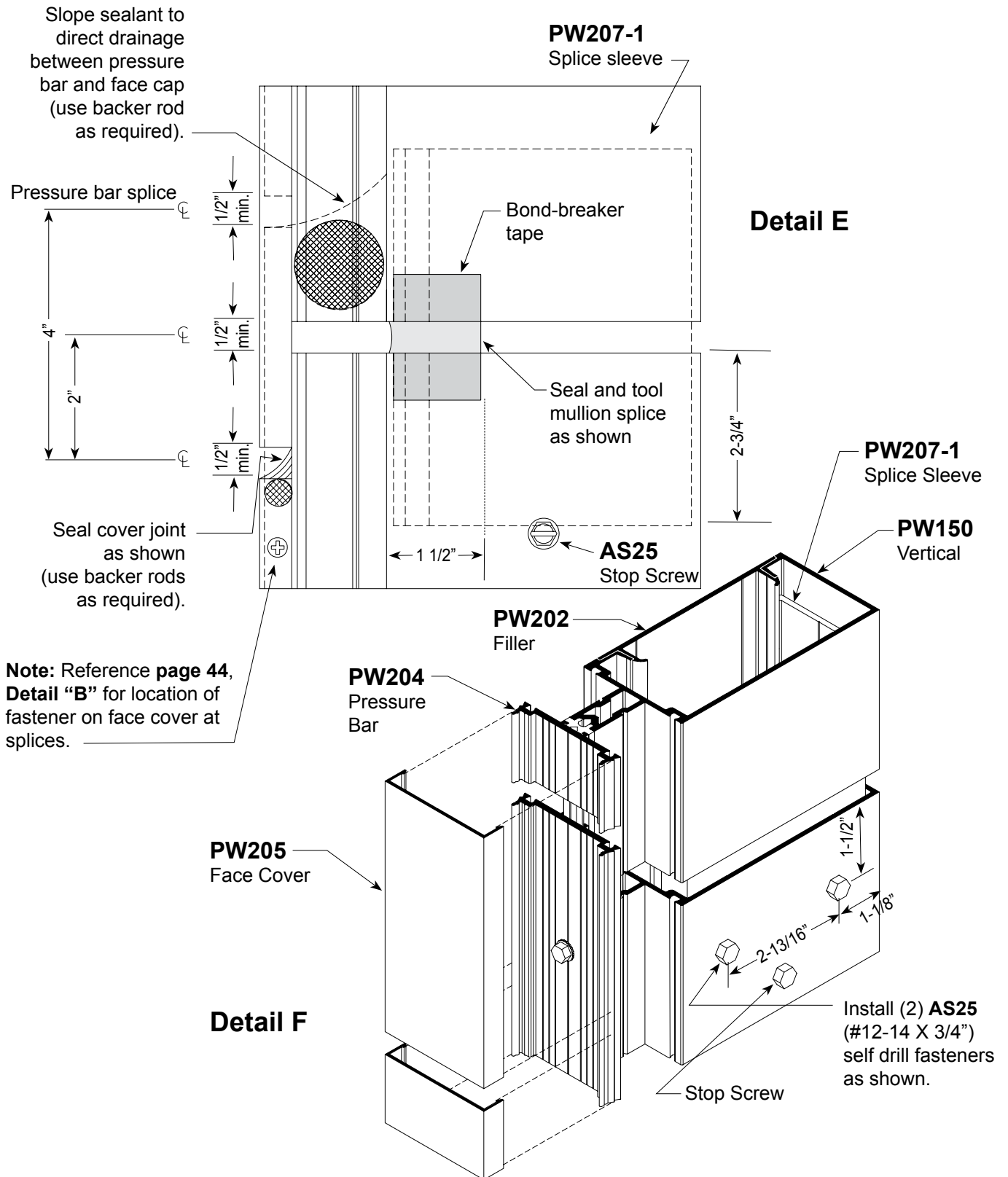

# FRAME INSTALLATION

## 1/4" Transition Glazing at Captured or B.G. Mullion

- STEP 1.** Apply sealant into gasket reglets before installing transition adaptors.
- STEP 2.** Install vertical adaptors first. Attach **PW215** with **AS27** fastener approximately 3" from each end and 18" O.C.
- STEP 3.** Notch horizontal adaptors at intersection of captured and B.G. verticals as shown. (See **Detail "B"**)
- STEP 4.** Install horizontal adaptors and seal horizontal / vertical joints. Tool Sealant.

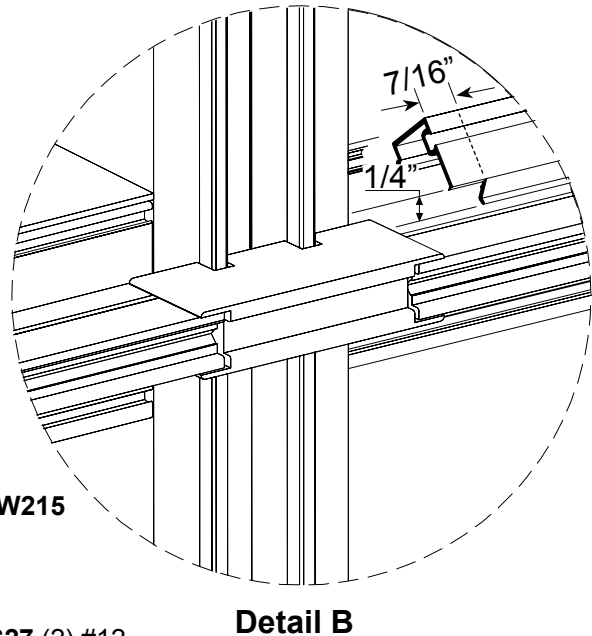
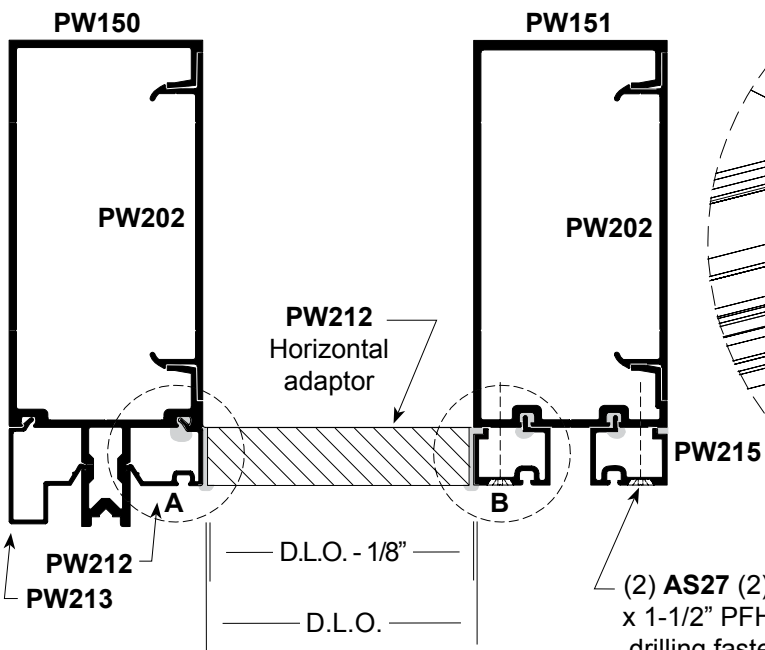
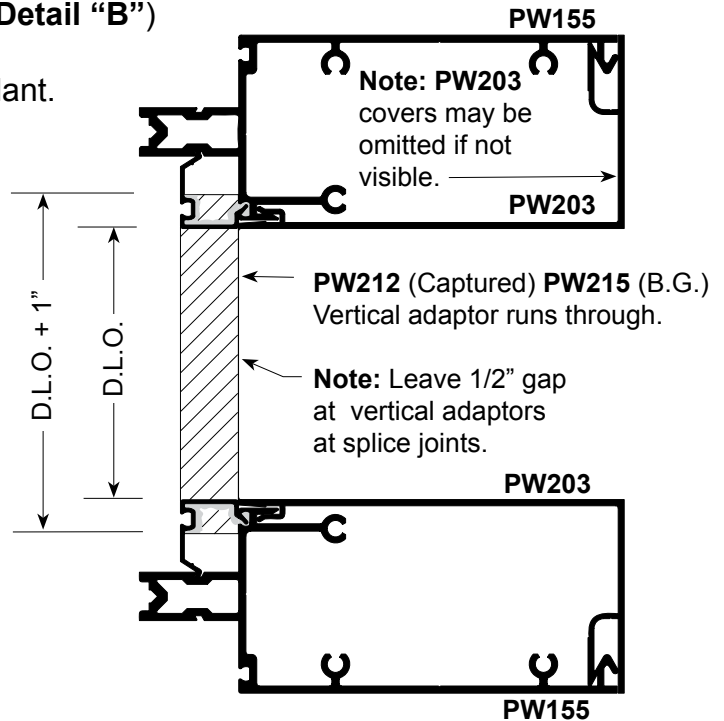
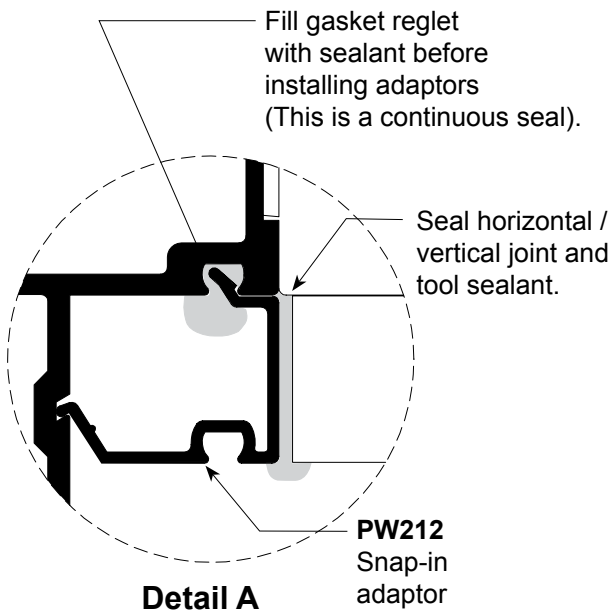

(2) **AS27** (2) #12 x 1-1/2" PFH self drilling fastener. (See **Step 2**).

# FRAME INSTALLATION B.G. Splice Sleeve

## STEP 1.

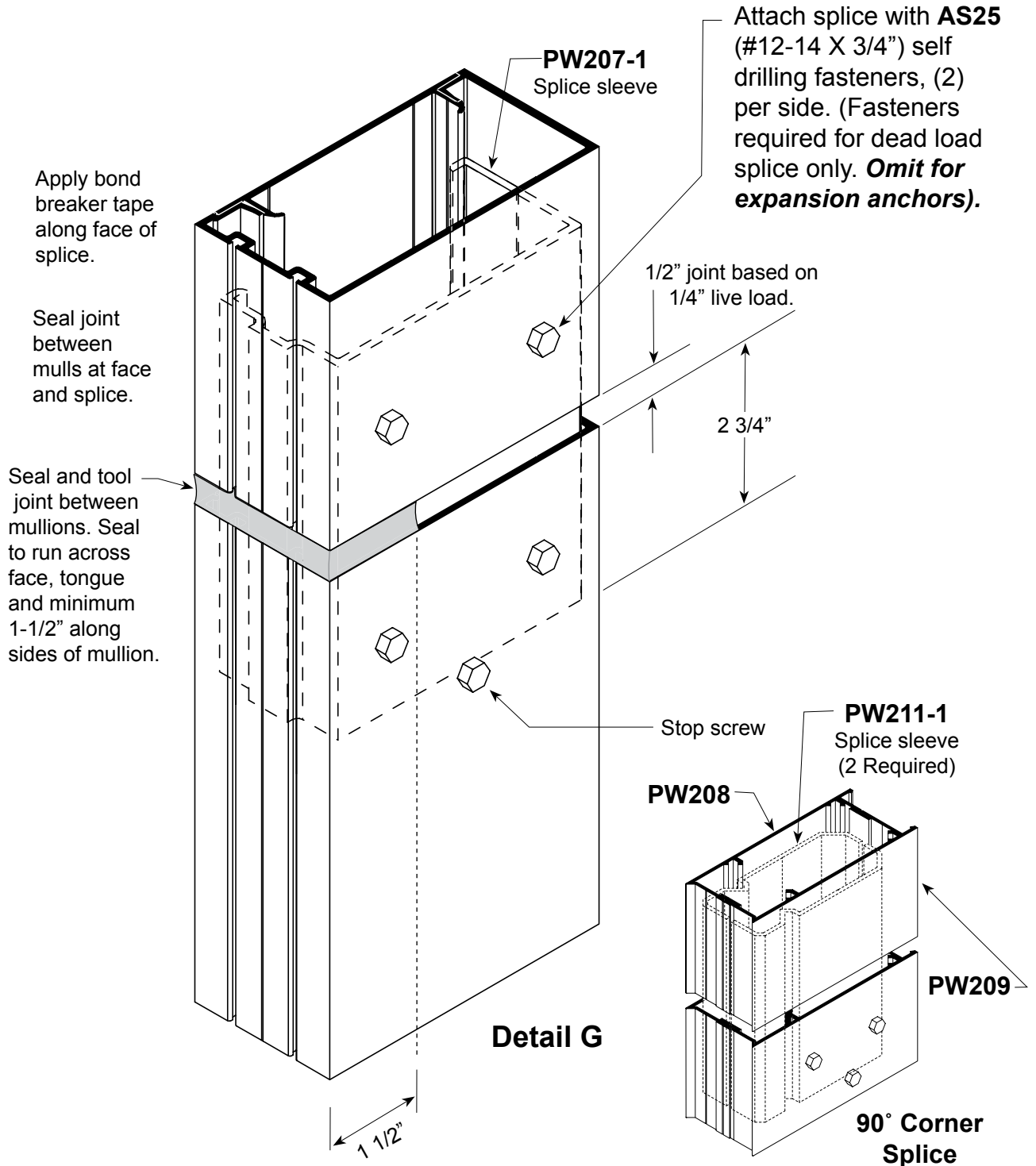

# FRAME INSTALLATION

## Splice Sleeve

### STEP 1.

Attach splice with **AS25** #12-14 X 3/4" self drilling fasteners, (2) per side. (Fasteners required for dead load splice only. **Omit for expansion anchors**).

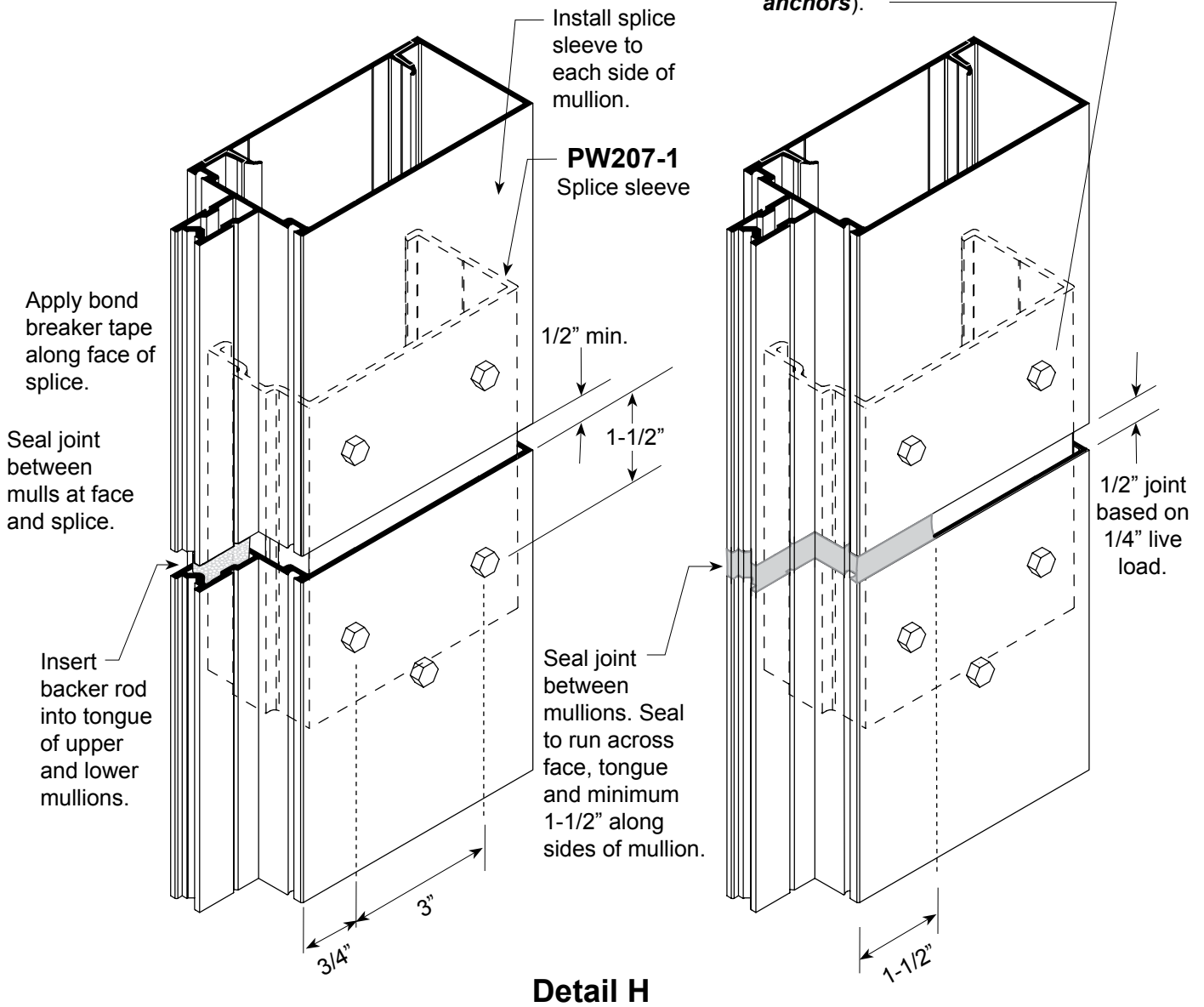

# FRAME INSTALLATION

## Vertical Mullion Splicing

**Note 1:** Do not install fasteners on upper half for expansion anchors.

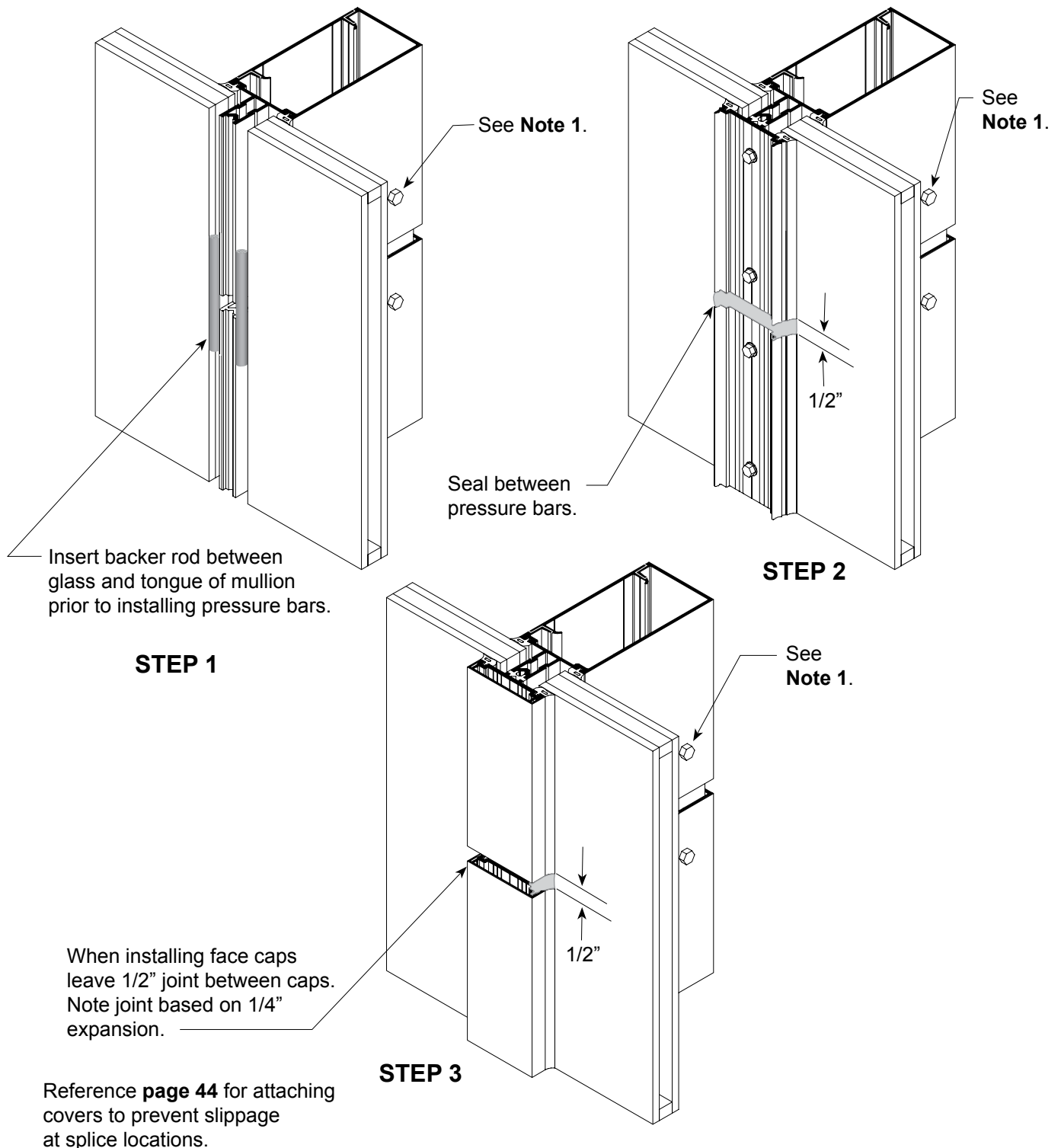



## FRAME INSTALLATION Perimeter Sealant Locations

**STEP 1.** Once all frames are installed and the system has been anchored to the substrate, apply weather seal around the entire perimeter. See details below for the correct location of the perimeter sealant and backer rod. **Interior** cosmetic seal is optional.

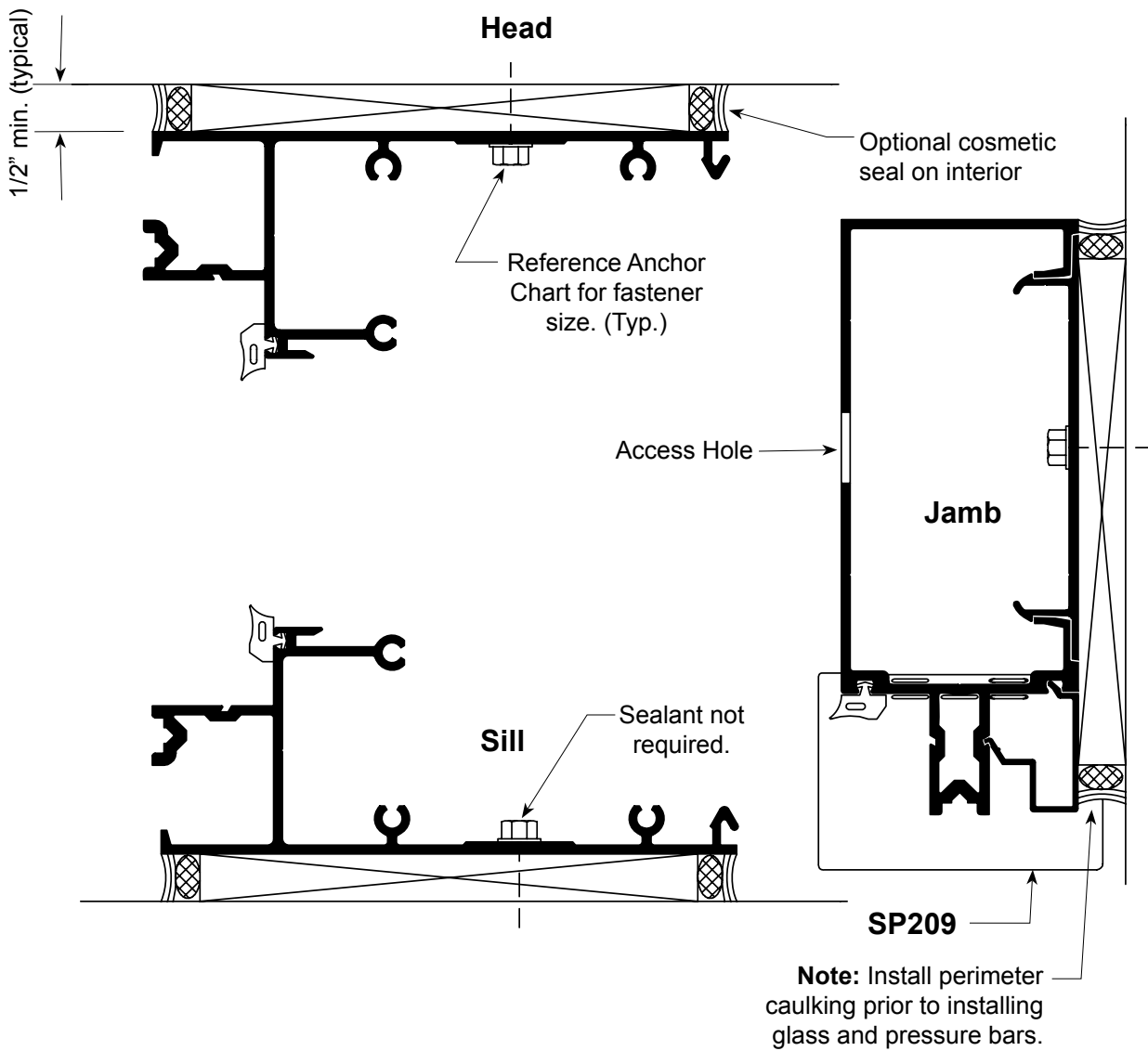

# FRAME INSTALLATION

## End Dams

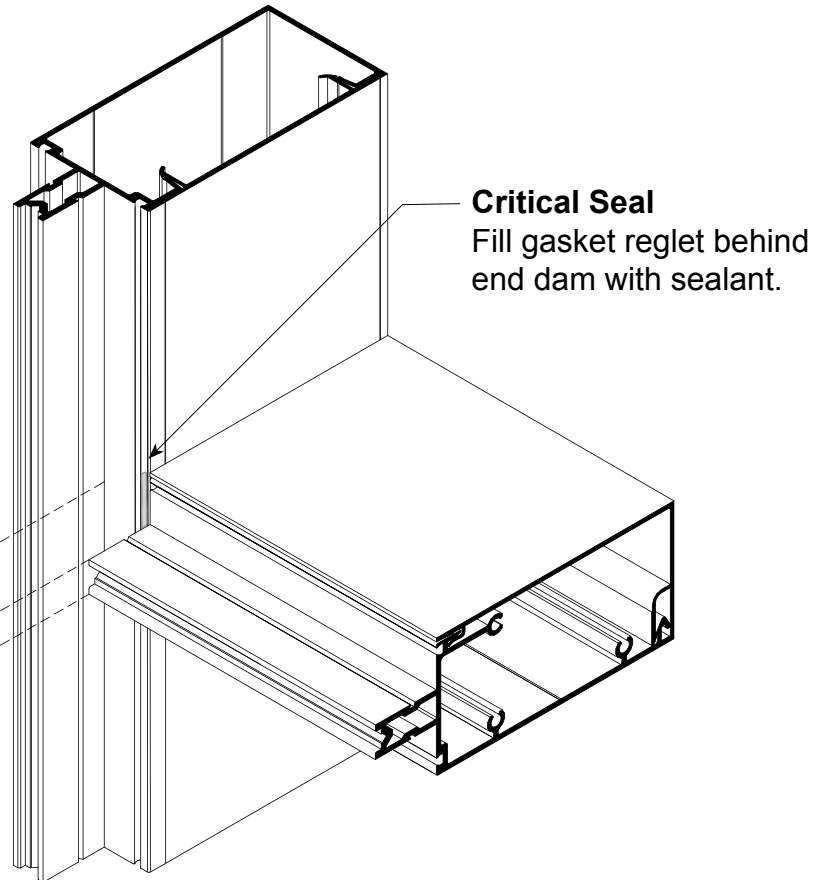

**Critical Seal**  
 Apply sealant to all three contact surfaces prior to installation as shown.

**SP203**  
 End Dam

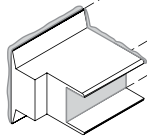

**Note:** SP203 End Dam required at all joints (head, sill, intermediate horizontals)

Force sealant into gasket reglet.

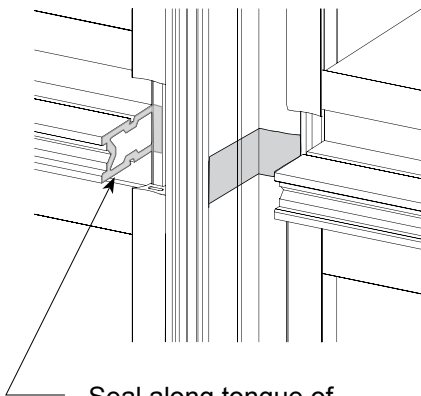

Seal along tongue of horizontal cross face and tongue of mullion before installing **SP203** end dams.

### STEP 1

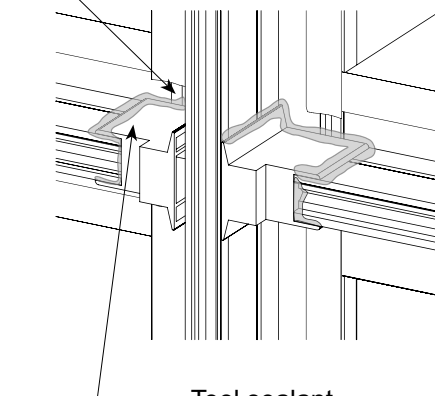

Tool sealant along top of end dam to form a water tight seal.

### STEP 2

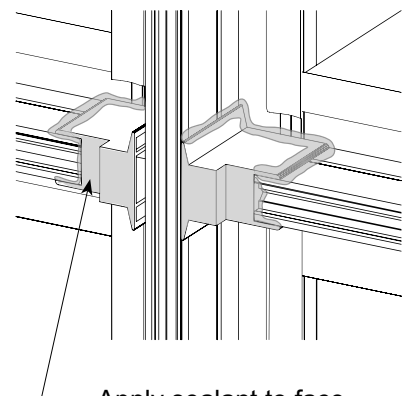

Apply sealant to face of end dam just prior to installing vertical pressure bar.

### STEP 3

## B.G. FRAME INSTALLATION Bridges

### Critical Seal

Apply sealant to all three contact surfaces prior to installation as shown.

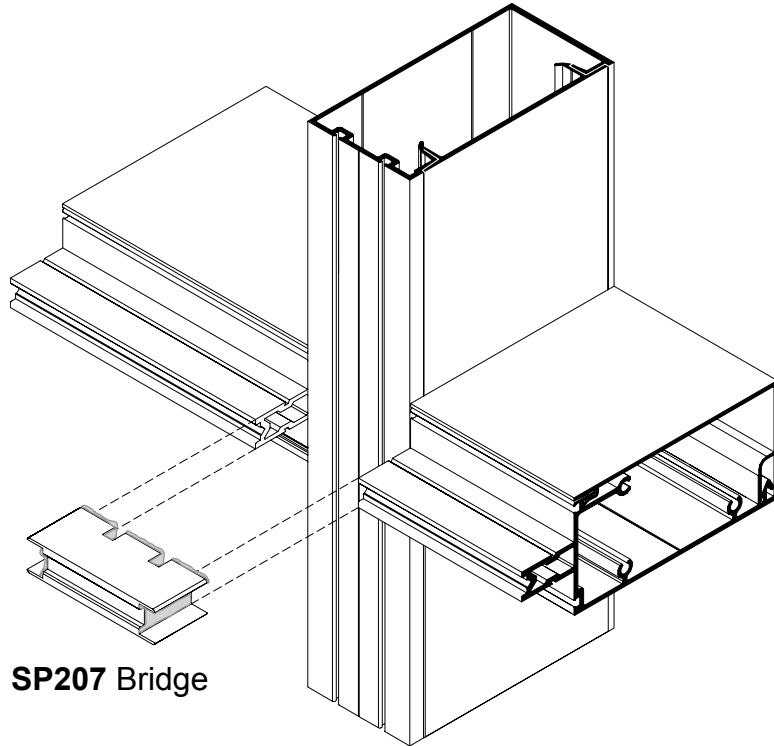

### NG14 Spacer gasket

Completely seal around **SP207** bridge and **NG14** gasket as shown.

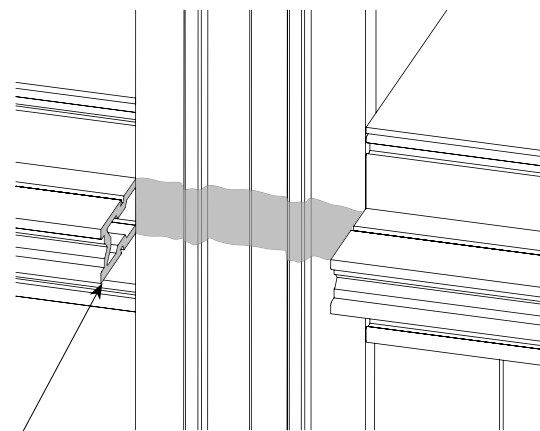

Seal along tongue of horizontal and across face of mullion before installing **SP207** bridge.

**STEP 1.**

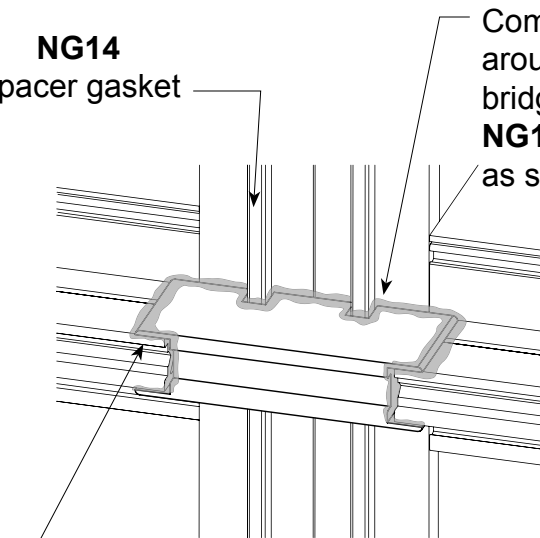

Tool sealant along top and sides of bridge to form a water tight seal.

**STEP 2.**

## GLAZING Setting Block Installation

Locate two setting blocks on each sill and intermediate horizontal member as shown. Reference **Dead Load Charts** for this system in *Architectural Detail* book and/or shop drawings for correct location based on glass size.

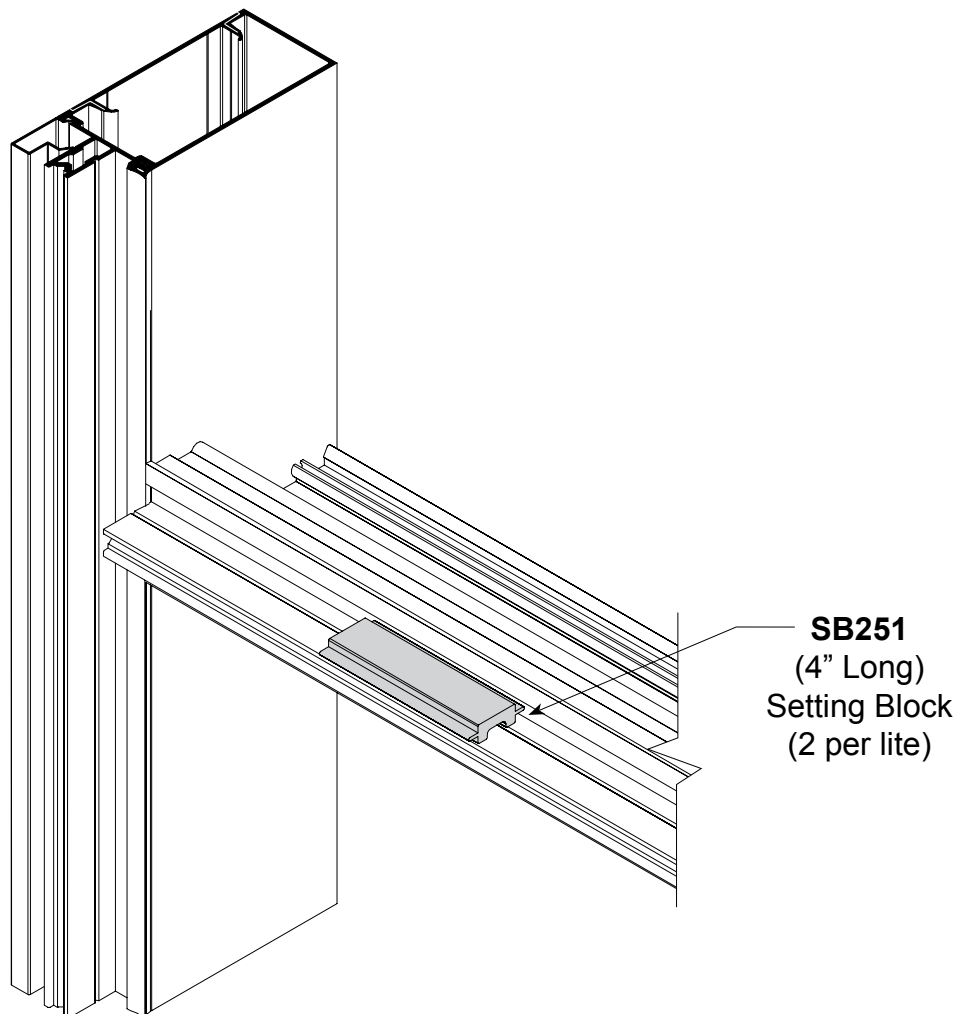

## GLASS SIZE FORMULAS Captured and B.G. Mullions

### Glass Sizes for Captured System:

Glass Width and Height = D.L.O. + 1"

### Glass Sizes for Butt Glazed System: (See Detail A below)

Glass Height = D.L.O. + 1"

Glass Width (Butt Glaze on Both Sides) = D.L.O. + 2"

Glass Width (Butt Glaze on One Side and  
 Captured on the Other Side) = D.L.O. + 1 1/2"

### Glass Width at 90° Corner:

With Captured Intermediate Vertical = D.L.O. + 1"

With B.G. Intermediate Vertical = D.L.O. + 1-1/2"

**Note:** Glass tolerances are not addressed in the above formulas. Consult the glass manufacturer for glass tolerances prior to ordering. Structural silicone must be applied from the interior and weatherseal from the exterior.

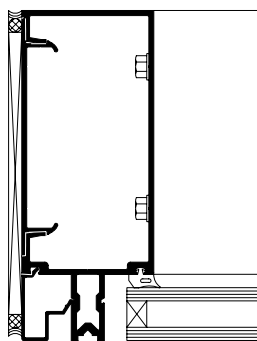

**WALL  
 JAMB**

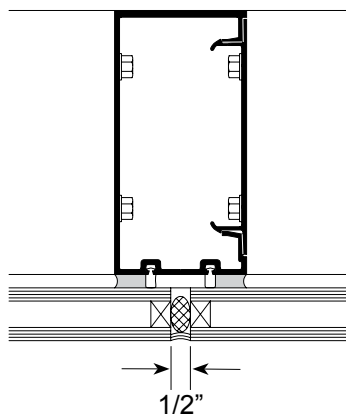

**INTERMEDIATE  
 B.G. VERTICAL**

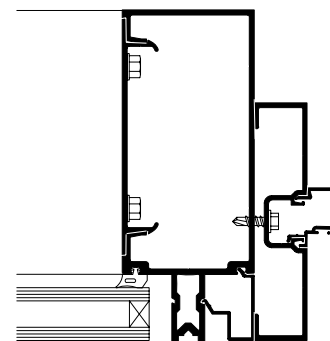

**DOOR JAMB**

**Detail A**

# GLAZING

## Sealant at Interior Gasket Corners

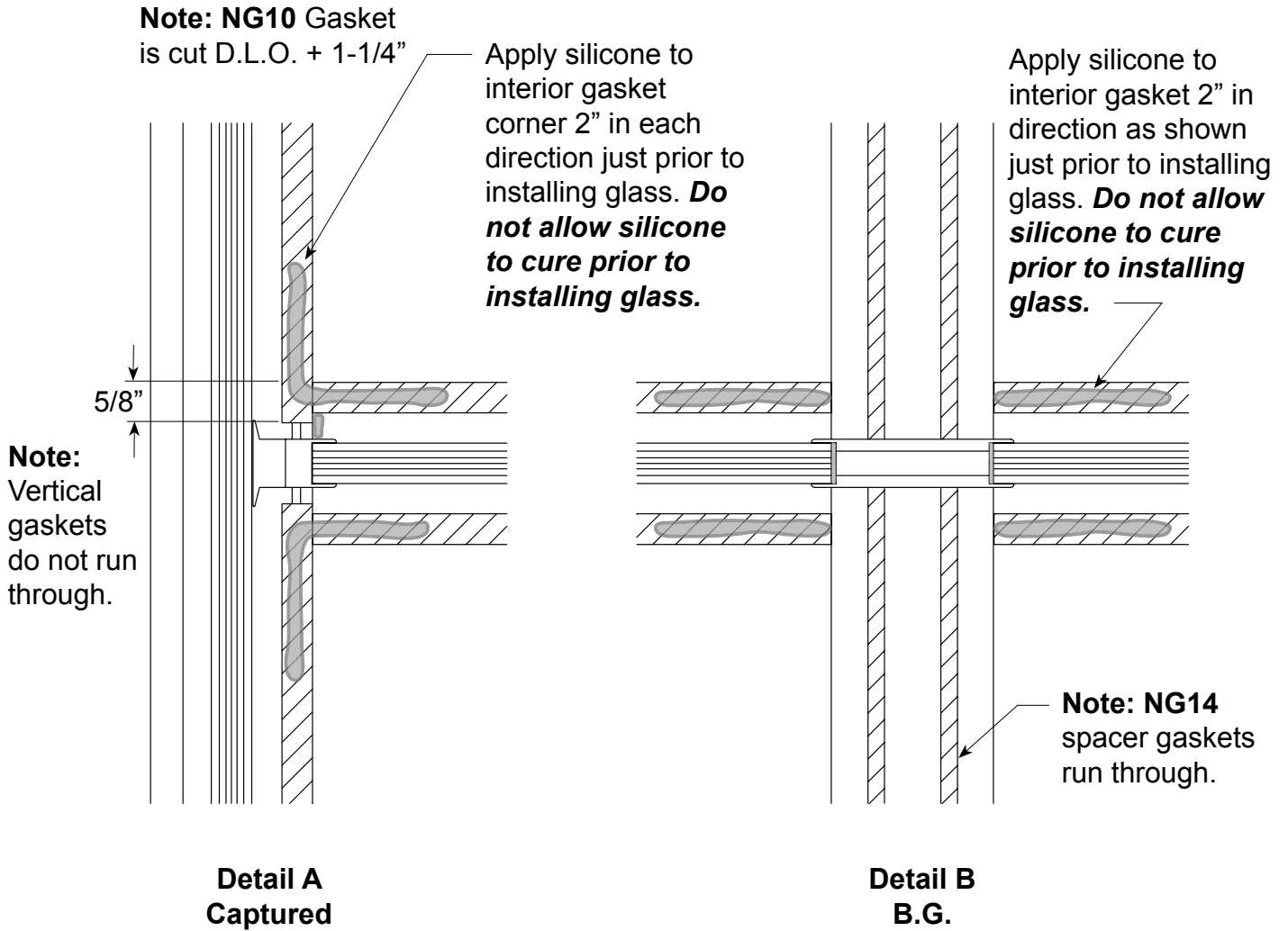

# GLAZING Glass Installation

## Step 1.

Install glass and center in opening. Retain glass with **SP253** temporary retainers. Retainers should remain in place until structural silicone has fully cured on B.G. Mullions.

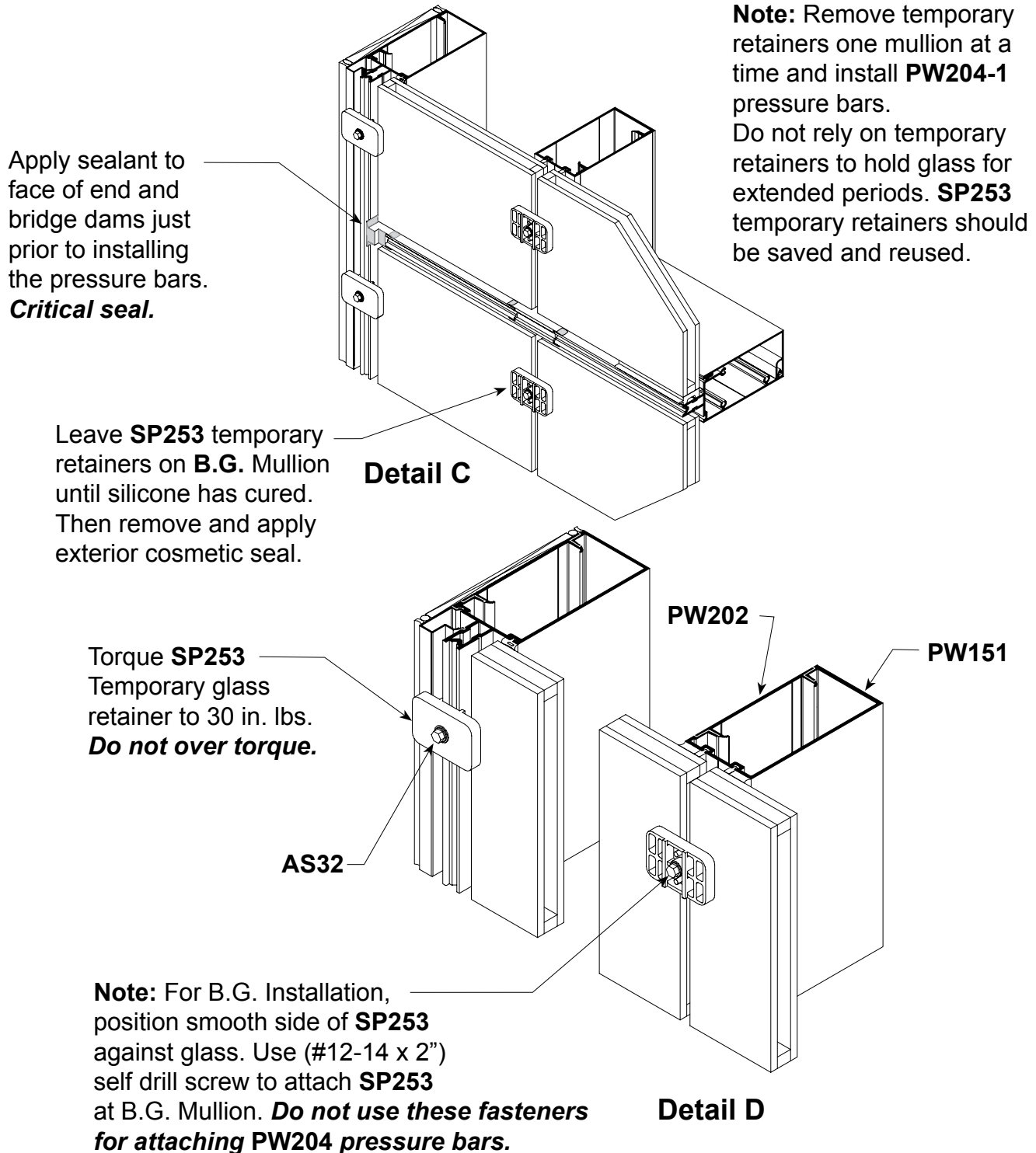

## GLAZING

### Pressure Bar Installation - Captured

Install **AS32** vertical pressure bar fasteners from bottom to top and horizontal pressure bar fasteners from center outward. Make sure one fastener is located 1-1/2" maximum from vertical/horizontal joint intersections to ensure proper pressure over end dams. **While installing pressure bar fasteners, take care not to disengage NG12 pressure bar spacer.**

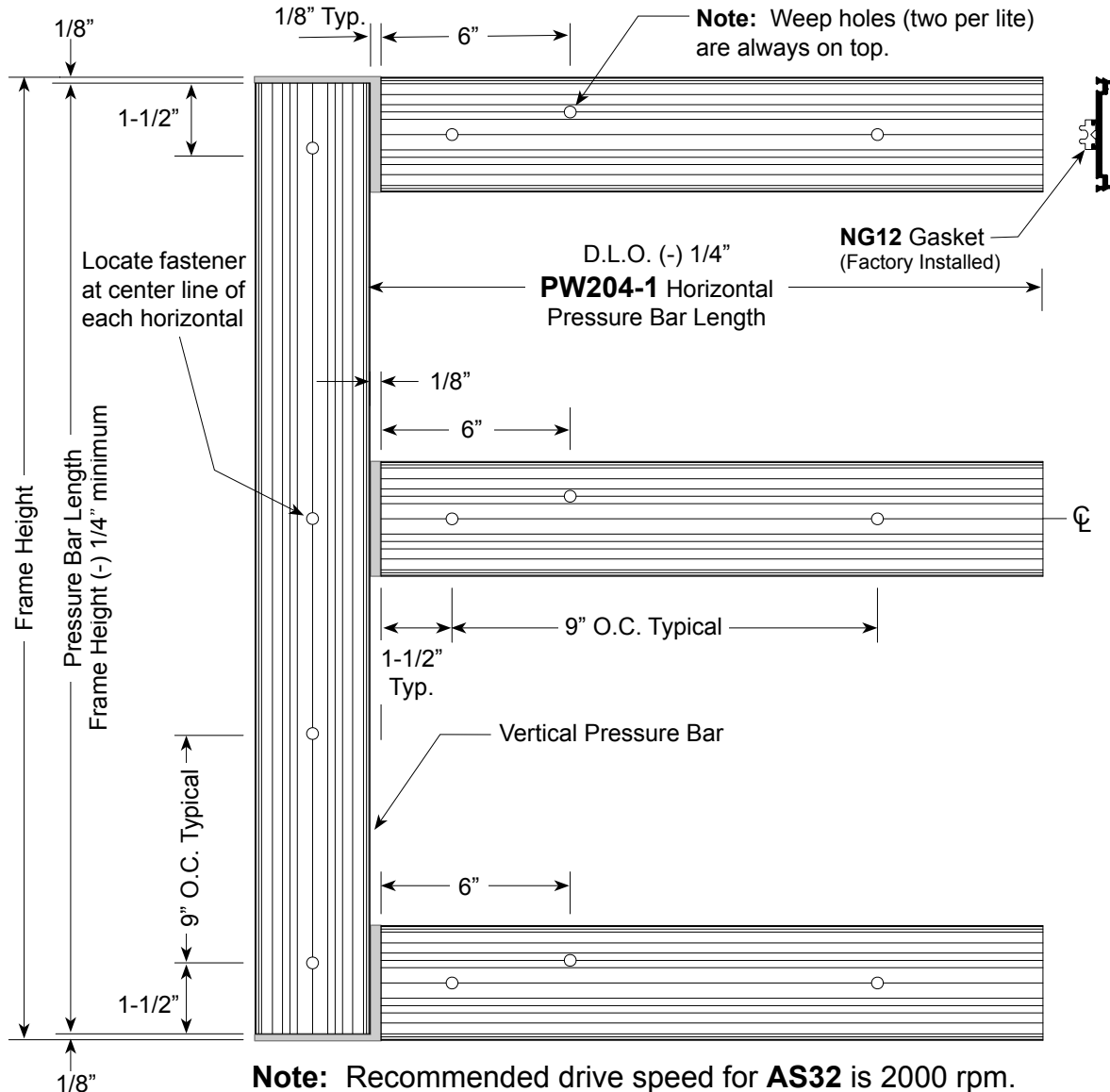

- Step 1.** Attach vertical pressure bars leaving a 1/8" gap at top and bottom with **AS32** (#12 x 1-1/4") #3 self-drilling fasteners. Using electrically powered hand held drill/driver, torque **AS32** fasteners to 85-90 in. lbs. If using battery power tools, *it is recommended that installer frequently check for accurate torque settings, as battery power will diminish over time.*
- Step 2.** Center horizontal pressure bars in opening leaving a 1/8" gap at each end and attach.
- Step 3.** Seal gaps at vertical/horizontal intersections and at top and bottom of vertical pressure bars.



## GLAZING

### Pressure Bar Installation - B.G.

Install **AS32** vertical pressure bar fasteners from bottom to top and horizontal pressure bar fasteners from center outward. Make sure one fastener is located 1-1/2" maximum from vertical/horizontal joint intersections to ensure proper pressure over end dams. **While installing pressure bar fasteners, take care not to disengage NG12 pressure bar spacer.**

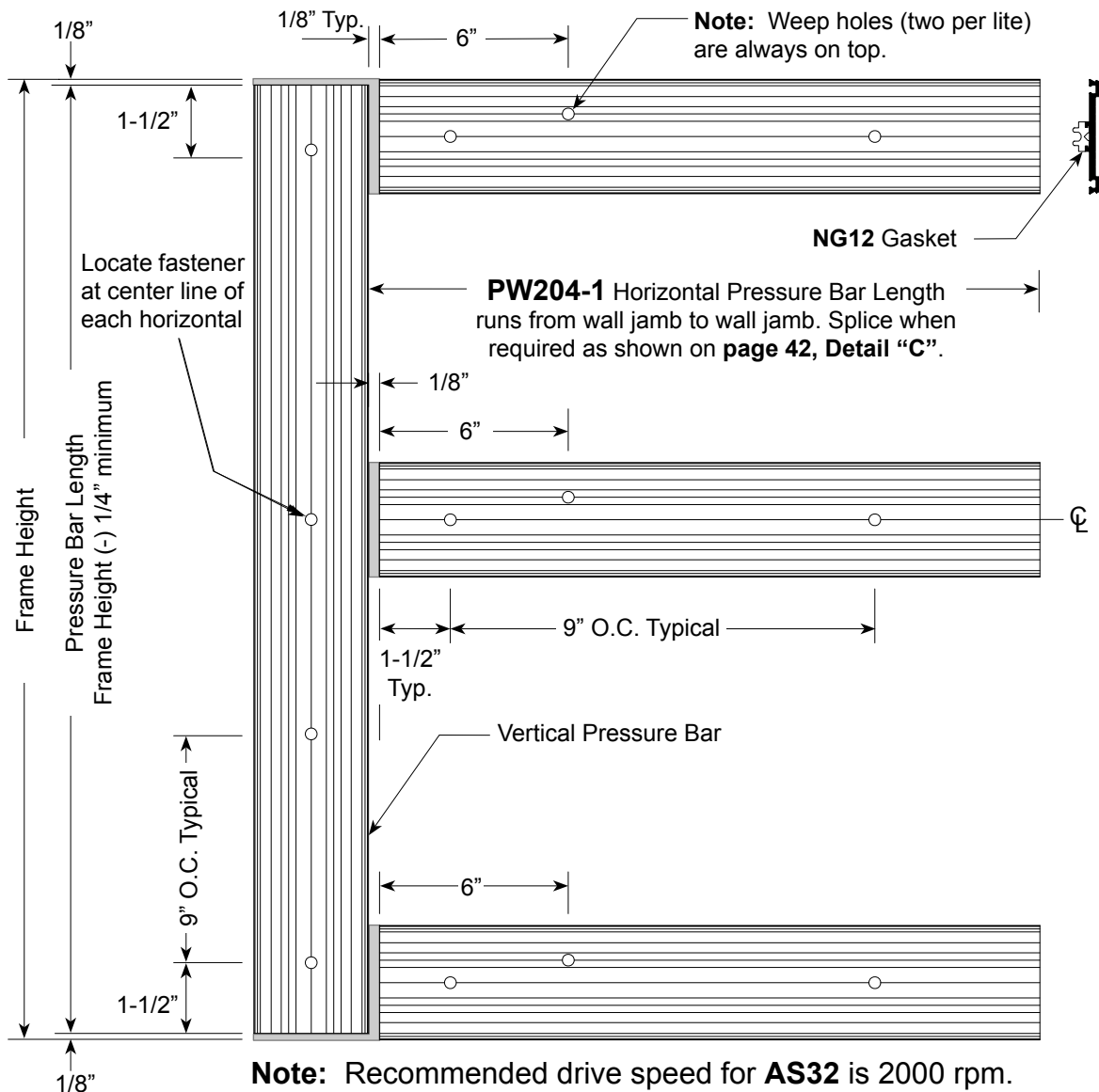

**Step 1.** Remove temporary retainers one mullion at a time. Attach vertical pressure bars leaving a 1/8" gap at top and bottom with **AS32** (#12 x 1-1/4" #3 self-drilling fasteners). Using an electrically powered hand held drill/driver, torque **AS32** fasteners to 85-90 in. lbs. If using battery power tools, *it is recommended that installer frequently check for accurate torque settings, as battery power will diminish over time.*

**Step 2.** Center horizontal pressure bars in opening leaving a 1/8" gap at each end and attach.

**Step 3.** Seal gaps at vertical/horizontal intersections and at top and bottom of vertical pressure bars.

## PRESSURE BAR INSTALLATION At B.G. Mullions

1. Remove temporary retainers one vertical at a time and install pressure bars using **AS32** (#12 x 1-3/4") #3 self-drilling fasteners and a cordless adjustable clutch driver/drill with a 3/8" driver. Torque fasteners to 85-90 inch pounds. Periodically check the torque setting on the adjustable clutch driver/drill.  
**Note:** Recommended drive speed for **AS32** is 2000 rpm.
  
2. Install wall jamb pressure bar fasteners from bottom to top and horizontals from center outward. Locate **AS32** fasteners 1-1/2" maximum from vertical/horizontal intersections to ensure proper pressure over end and bridge dams.  
 Reference **Step 8, page 12**.
  
3. Remove temporary retainers from horizontals, one bay at a time, and center horizontal pressure bars in opening leaving 1/8" gaps at ends and 1/2" at splice joints. Attach with **AS32** fasteners, reference **page 41** and **Detail "A"** below.
  
4. Upon completion of pressure bars installation and just prior to installing face covers, seal all gaps at intersection of vertical/horizontal pressure bar joints and tool the sealant.
  
5. Seal between pressure bar & face cover splices. Keep sealant away from face cover snap area.

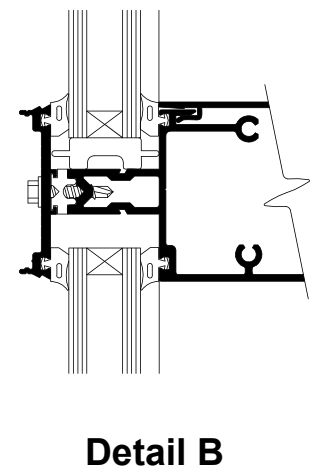
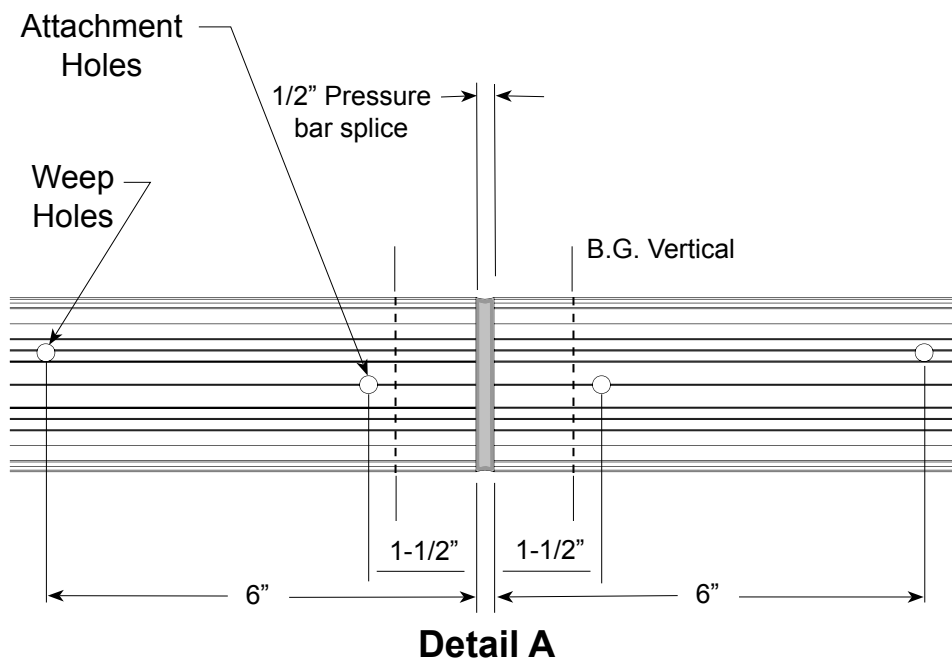

Pressure bar splicing & sealing at B.G. Mullions  
*(Intermediate Horizontal shown; Head & Sill similar)*

## HORIZONTAL FACE COVER Splice Joints - B.G. Installation

1. Locate 1/2" wide splice joints at center line of vertical members.
2. Do not align face cover splices directly over pressure bar splices. Offset 6" minimum.  
See **Detail "C"**.
3. Set backer rod between face cover and pressure bars at joint and seal. Tool sealant.  
See **Detail "D"**.

**Note:** Pin one end of each face cover with **AS31** fastener to prevent slippage. Reference **Detail "C"** on page 44.

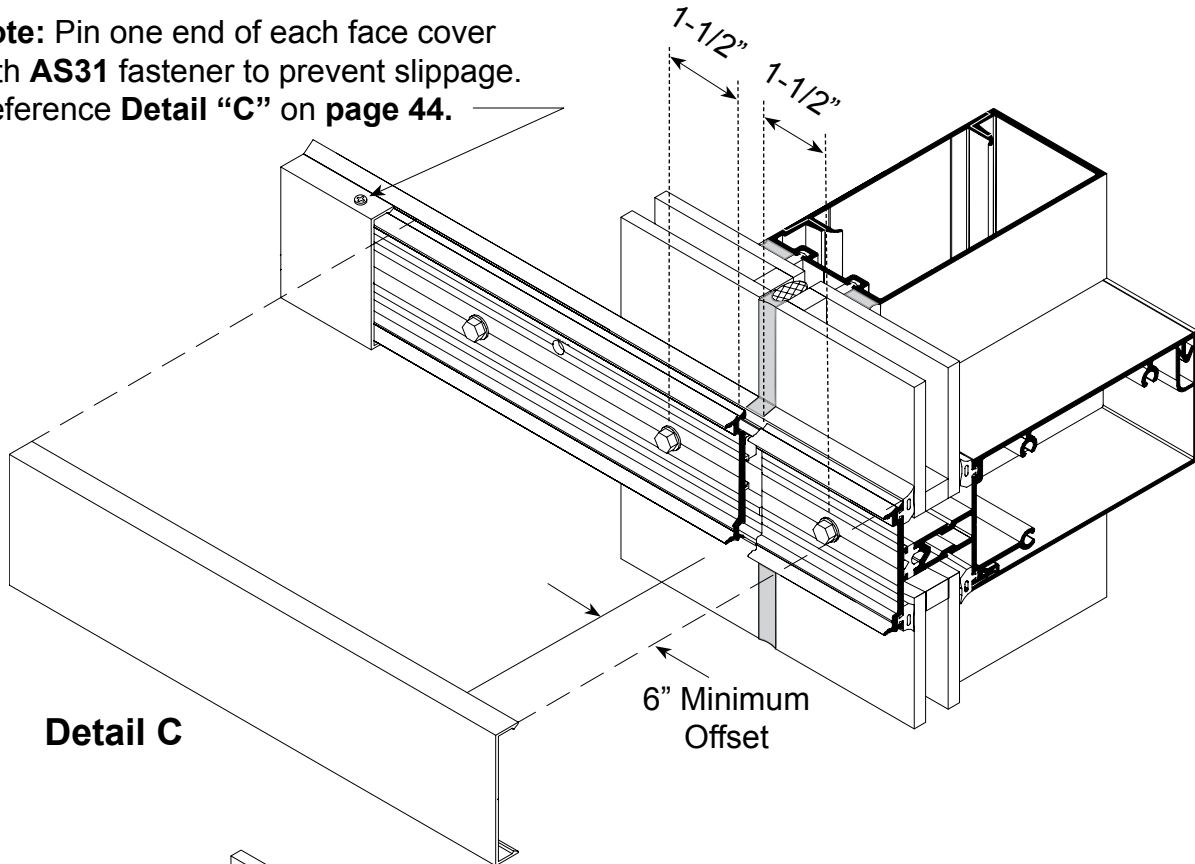

**Detail C**

6" Minimum  
Offset

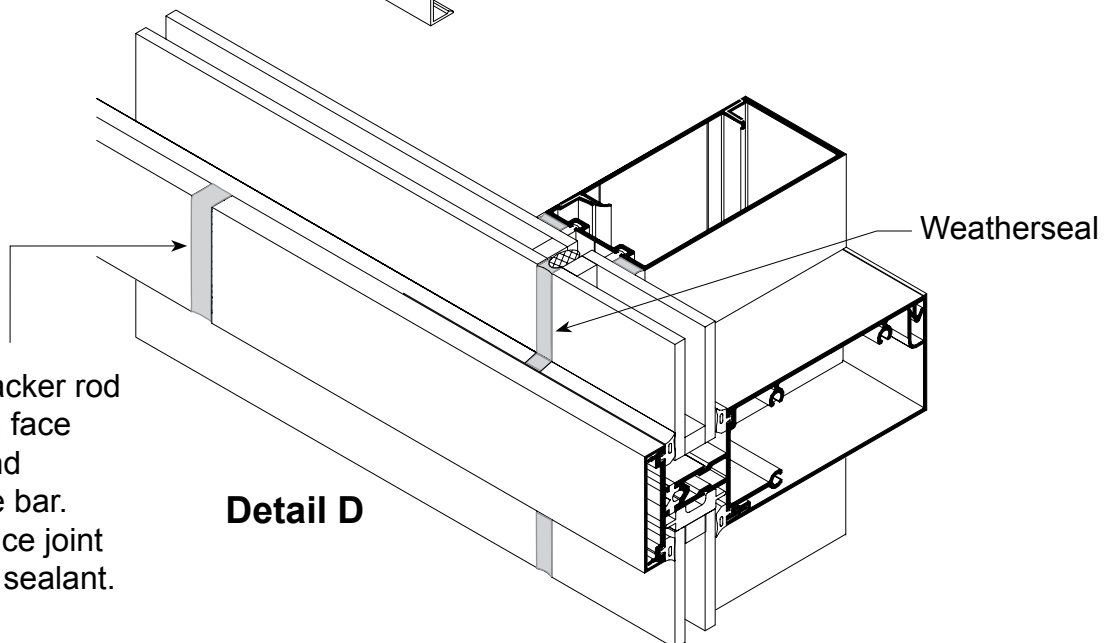

**Detail D**

Weatherseal

Insert backer rod  
between face  
cover and  
pressure bar.  
Seal splice joint  
and tool sealant.

## FACE COVER INSTALLATION

1. Care must be taken to prevent damage of face covers during installation. Use a piece of wood such as 2" x 4" approximately 8-10" long and a 3" diameter Stanley 3 lb. Compo-Cast dead blow soft face hammer.
2. Install vertical face covers first. Do not displace top and bottom mullion caps when installing face covers. Pinning of vertical face cover is required to prevent slippage. Use one **AS31** on each side per cut length, concealed behind horizontal face cover as shown. See **Detail B**.
3. Install snap-in horizontal face covers with the weep holes located on the bottom side.
4. Horizontal face covers exceeding 1-1/2" in depth must be pinned on top side with **AS31** fastener to prevent disengagement. Locate one fastener at mid-point for 3-5 ft. lengths. On longer lengths, locate at 3'-0" O.C. See **Detail C**.

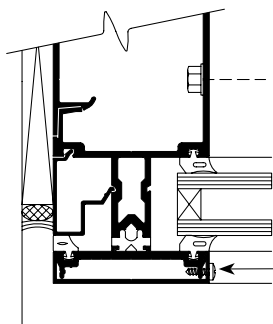

**AS31** (#6 x 3/8"  
 PPH Type AB pt.)

**Detail B**

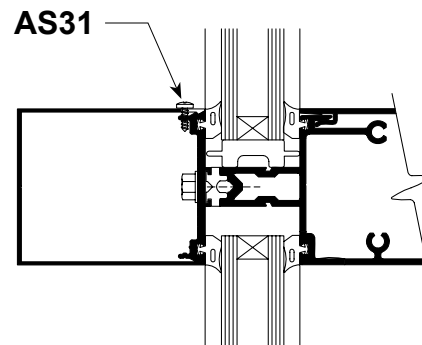

**Detail C**

## SEALING MULLION END CAPS Top and Bottom (Top Shown - Bottom Similar)

**SP209**  
 Mullion  
 End Cap

1. Seal top and bottom of each vertical mullion end cap as shown.  
**Note:** Vertical face covers are cut mullion length -1/4". Leave 1/8" gap at top and bottom.

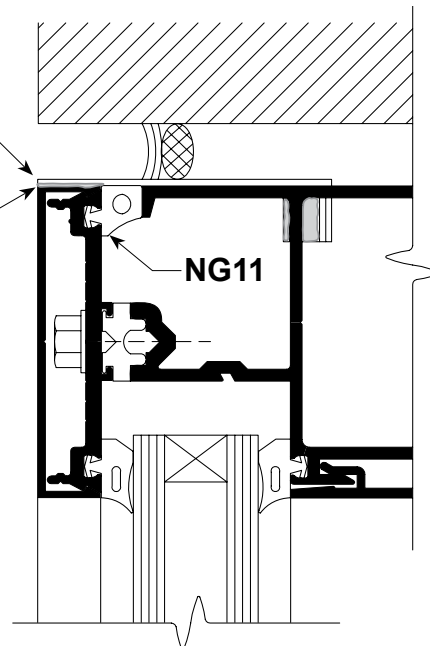

**Detail A**

# INTERIOR TRIM INSTALLATION

## Checking Joinery Seals and Anchor Bolts

**Note:** Interior trim covers may be omitted in spandrel areas when not visible from interior.

**Step 1.** Check seals at all vertical/horizontal joints and reseal if required.

**Step 2.** Check all perimeter anchor bolts to make sure they are installed and secure.

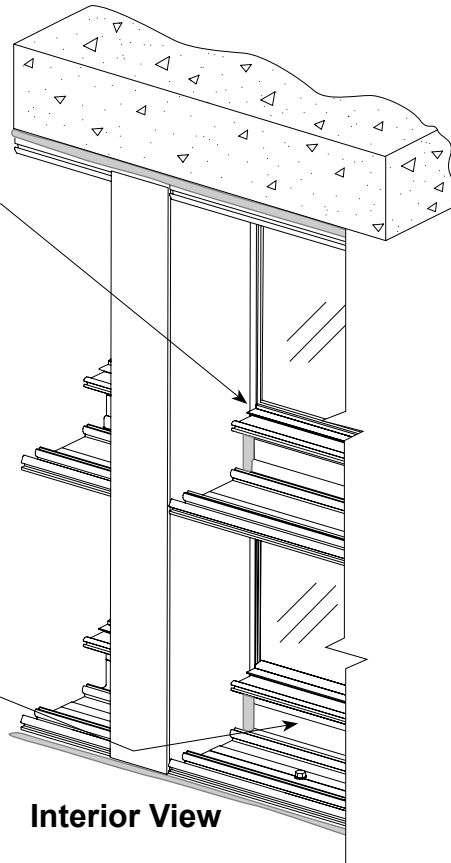

**Detail A**

**Step 3.** Insert **PW203** interior trim cover into receiver and snap downward into place. Use dead blow mallet and wooden block as required. Take care not to ding or bend cover.

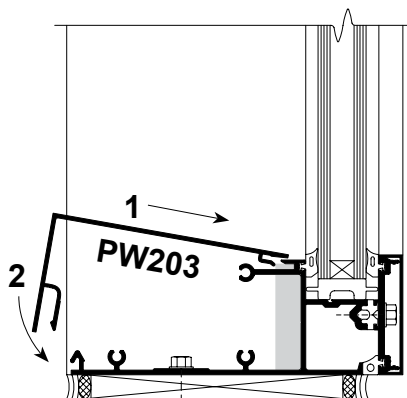

Sill shown, head and horizontal similar.

**Exterior View**

**Detail B**

## ENTRANCE SUBFRAMES

**Note:** Refer to **FRAMES & ENTRANCES** section of this manual for additional fabrication and installation instructions. Entrance Frames may be installed simultaneously with Curtain Wall or after Curtain Wall installation has been completed.

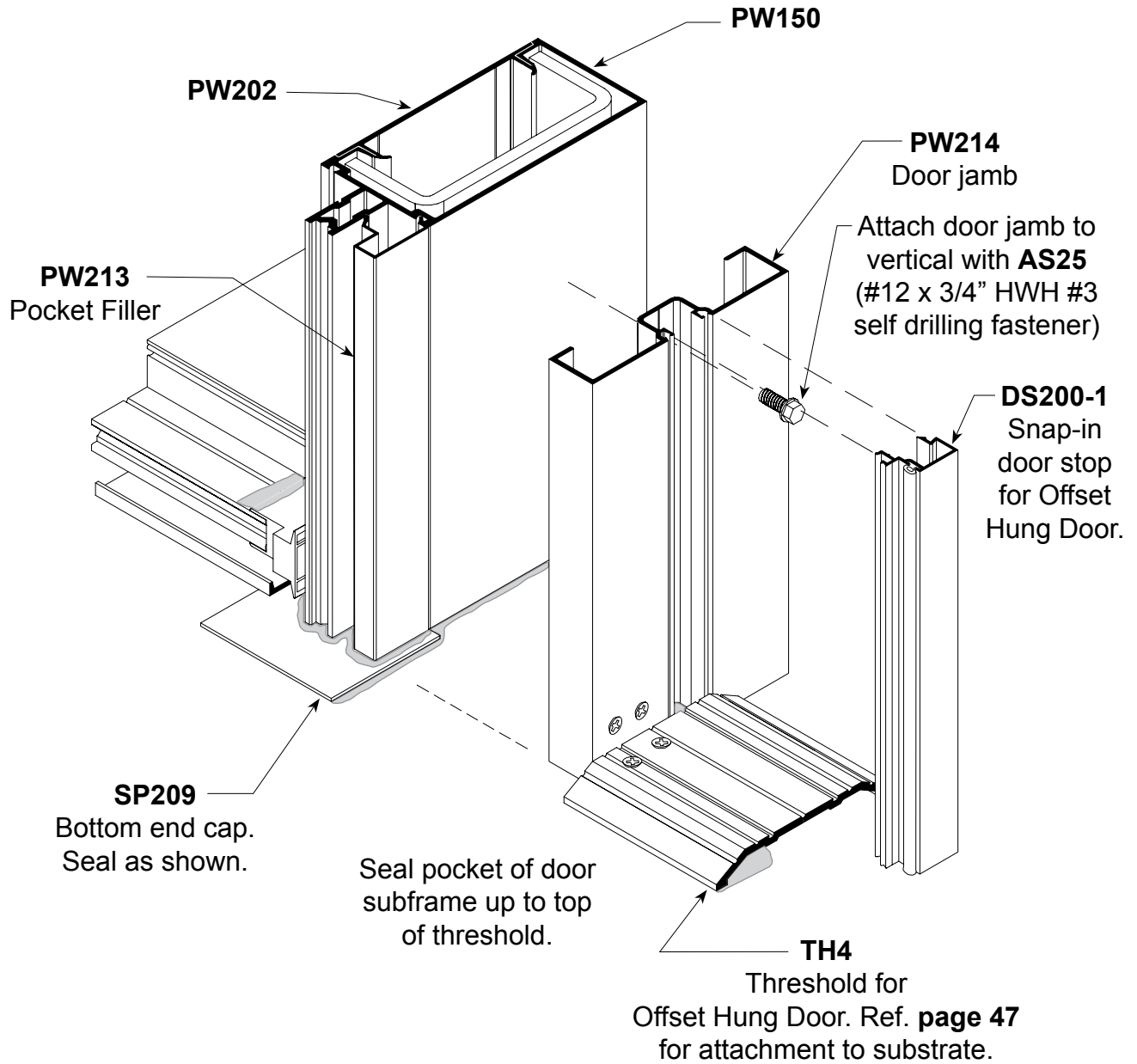

### Offset Hung Door

# SUBFRAME FASTENER CHART

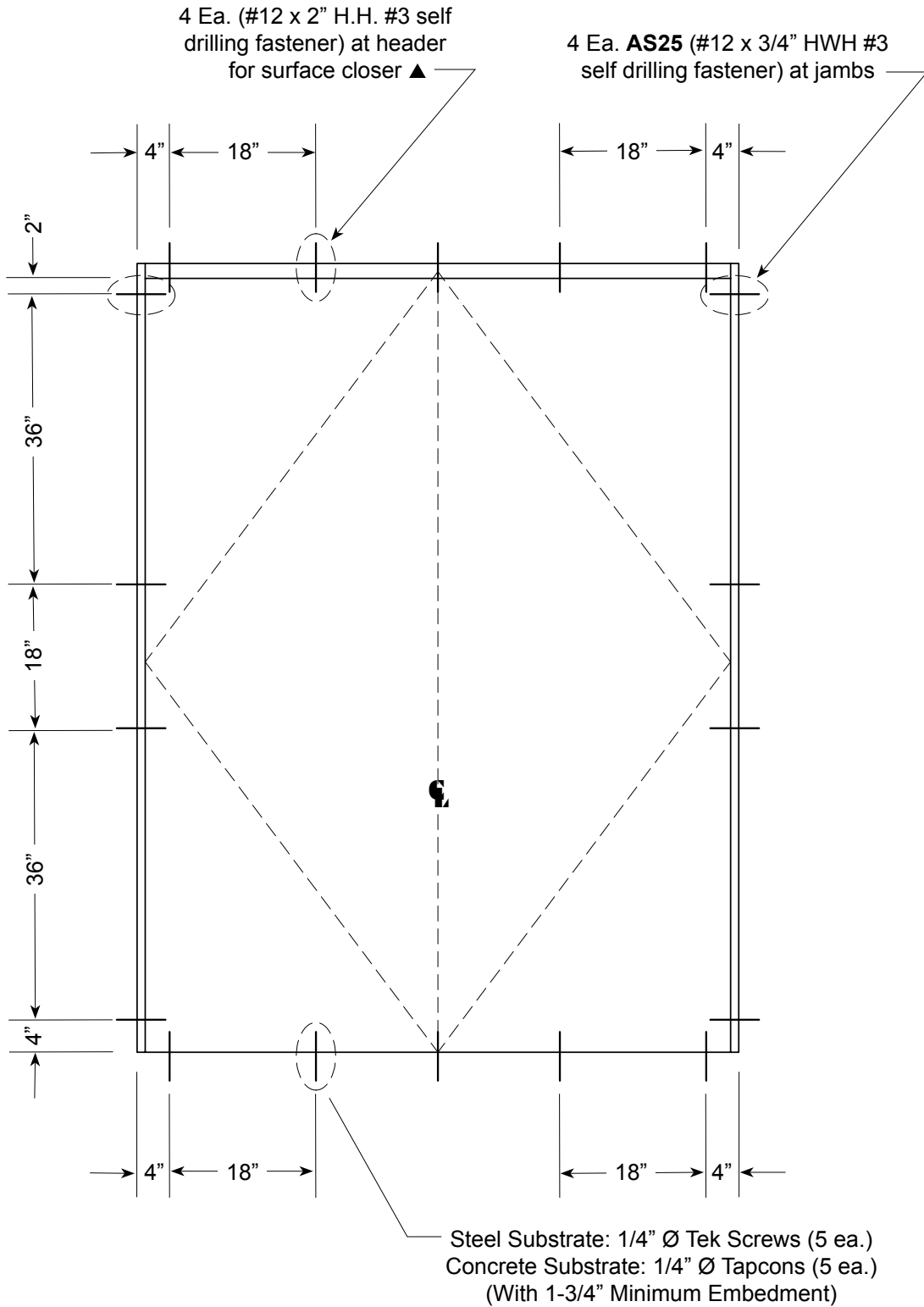

▲ For C.O.C. Tubular Header, use 4 ea. **AS25** with access holes concealed under **DS202-1** offset arm cover.

